

FORMAX[®]

FD 125
Large Format Card Cutter

Table of Contents

SAFETY PRECAUTIONS	3
Introduction.....	4
Specifications.....	4
Accessories	4
Major Components and Assemblies.....	5
Control Panel	5
Setting Up Procedure	8
The Job selection	10
Optional Slitter.....	11
Job Layout.....	12
Registration Mark Position	15
Selecting a job.....	15
Batch Count function.....	16
User Define Job.....	16
Turbo and Normal Mode	17
Reset Counter	18
Clear Jam	18
Pure Dark Image "Top Margin" Adjustment.....	19
Tip for Paper Weight Greater than 300gsm.....	20
Installation of Optional Slitter.	22
Optional Conveyor Item List.....	23
Optional Conveyor Installation.....	24

SAFETY PRECAUTIONS

Always observe the cautions and warnings given below to prevent personal injury or property damage.

⚠ WARNING:



Always pull the power supply plug out of its outlet before removing jammed paper.



Do not use supply voltage other than the specified voltage.



Do not insert pins, wire or other foreign objects into the machine. Do not allow any liquid to get into the machine through its openings or gaps in its structure.



Do not modify the machine. Do not remove any of the covers from the machine..



Keep this unit and the power cord away from heaters and heater vents. Excessive heat could melt the cover or power cord covering, and result in a fire or an electrical shock.

⚠ CAUTION:



Do not put fingers inside during operation.
Keep away long hair, ties, jewelry and loose clothing.



Install this unit on a level, stable stand or floor, with sufficient space around it.



Do not install this unit in a location where there is excessive humidity or where contact with water is possible.



Disconnect the power plug from the power outlet before attempting to move this unit. Failure to do so could result in power cord damage, a fire or an electrical shock.

INTRODUCTION

The FD 125 is designed to simplify business card, photo and post card cutting in a single pass.

SPECIFICATIONS

Paper Size	LT, LG, LD, 12 x 18 and 13 x 19
Paper Weight	120 ~ 300gsm and Maximum<0.4mm
Feeder Capacity	120 sheets (300gsm)
Receiving Tray	250 business Card x 3
Speed	Up to 240 business cards/min Based on 55x90mm in A3
Accuracy	± 0.2 mm
Dimension	98.5 X 53.5 X 101.5CM (38.8x21.1 x 40")
Net Weight	61.2Kgs (135 lbs)
Power	115/230V Selectable, 50/60Hz, 1.2A

ACCESSORIES

Make sure all accessories are included with the machine.

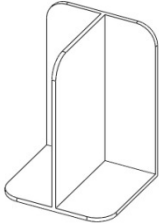
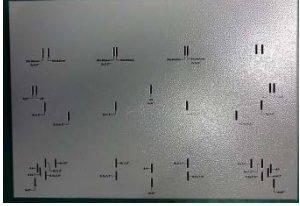
		
Power Cord	Stacking Guide x 4	Stacking Tray
Operation Manual		

KEY COMPONENTS

1	Cutter
2	Stand
3	Conveyor Optional

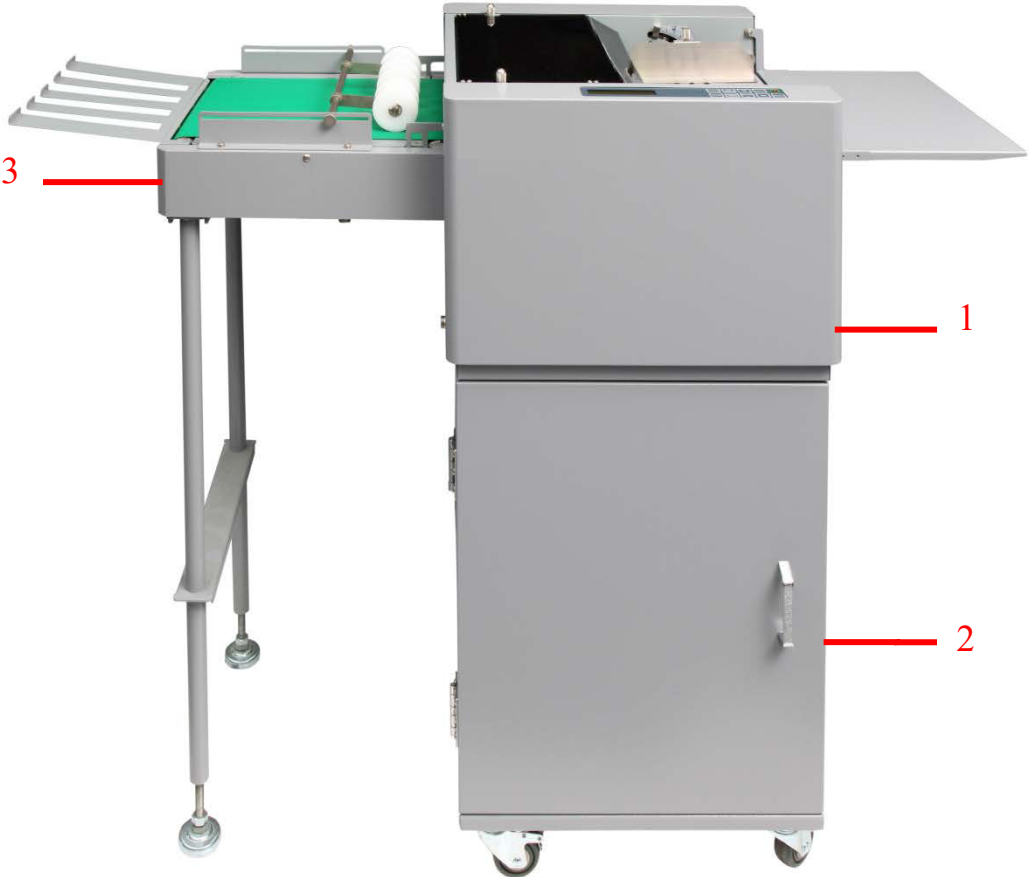



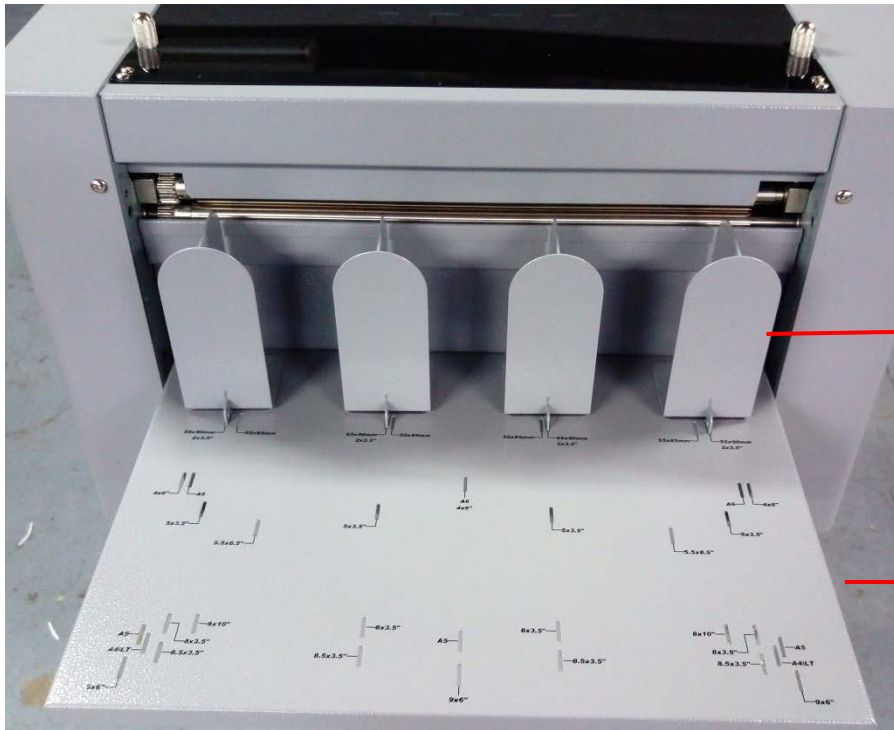
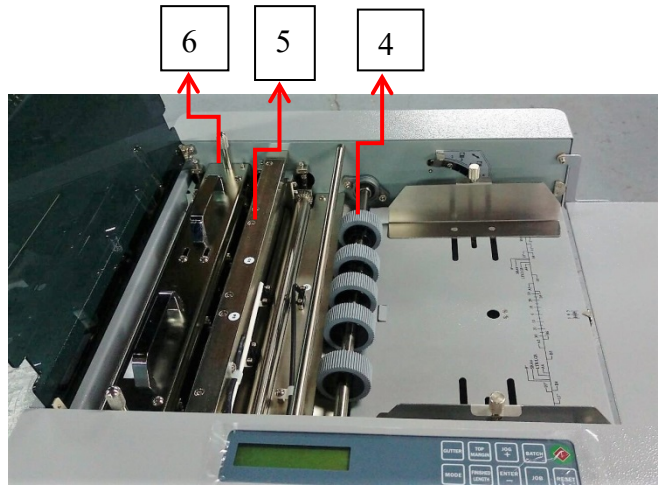
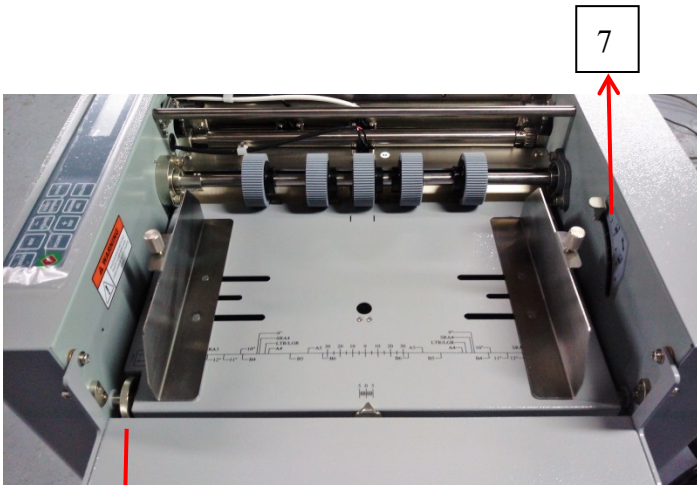



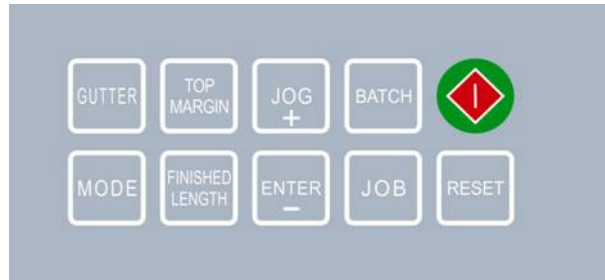

4	Feed Roller
5	Cutter Asm
6	Slitter Cassette
7	Feed Tray Tension Scale
8	Slitting Center Adjustment
9	Stacking Divider
10	Stacking Tray



CONTROL PANEL



Keys	Function
	<ul style="list-style-type: none"> Start and Stop the cutter
	<ul style="list-style-type: none"> Change job Toggle between “Normal Mode” and “Turbo Mode” (Paper Weight Setting Mode)
	<ul style="list-style-type: none"> Select batch count Pre-feed (Mark Reader Calibration Mode)
	<ul style="list-style-type: none"> Jog forward Increment settings by 0.1 mm when pressed.
	<ul style="list-style-type: none"> Confirm job and batch count setting. Decrement settings by 0.1mm when pressed (Mark Reader Calibration Mode). Jog backward Reset counter (use with “RESET” button simultaneously)
	<ul style="list-style-type: none"> Save settings Hold (4s) paper weight setting mode Reset counter (use with “ENTER” Button simultaneously)
	<ul style="list-style-type: none"> Enter program mode Change paper weight
	<ul style="list-style-type: none"> Set top margin
	<ul style="list-style-type: none"> Set finished length

SETTING UP PROCEDURE

1. CUTTER INSTALLATION

Note: No tool is required for installation.

Stack Tray

Place the stacking divider and the stacking tray indicator shown.

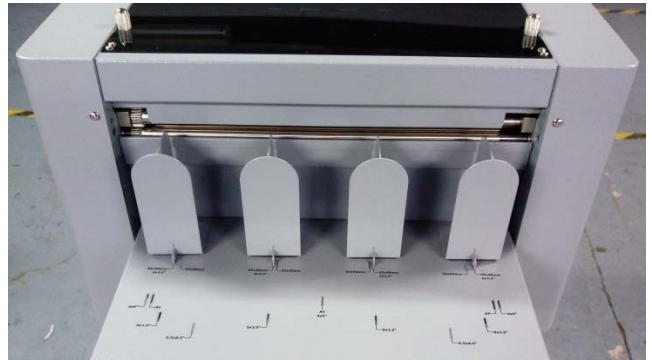



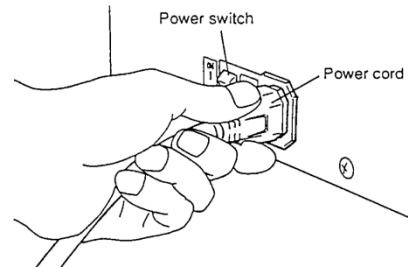

Power Cord

Use **caution** when plugging in power cord. Plug power cord to the machine and plug the other end into the wall outlet. Make sure the power selectable switch is 230V selected

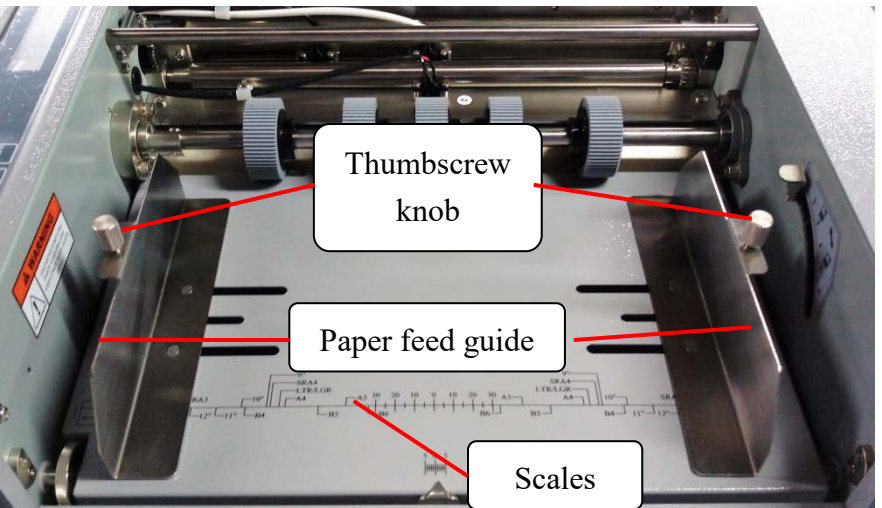

2. SETTING UP PROCEDURE

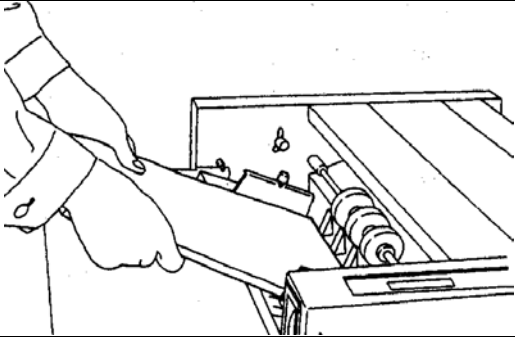
1	 <p>To set the width of paper, loosen thumbscrew knob on the side guide and slide to position. Use scales as reference point.</p>
2	 <p>Fan paper before loading. This will reduce static and toner adhesion due to printing. For best result, the paper stack should be flat.</p>

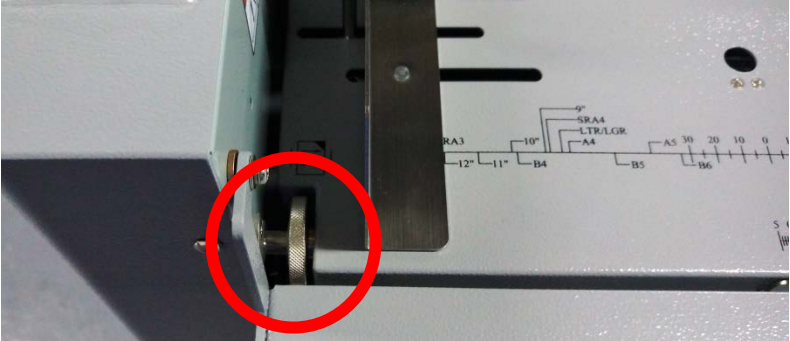
3	<p>Push the feed tray down and load the paper. Readjust paper guide if needed.</p>	
4	<p>Adjust tray pressure. For thinner paper, the number should be higher. For heavier paper the number should be lower.</p>	
5	<p>Use slitter registration adjustment knob to compensate for printing registration. The knob will allow $\pm 2\text{mm}$ of adjustment.</p>	

The Job selection

FD125 offers 7 different types predefined jobs from #01 to # 07 and 6 programmable job #08 to #13. The standard cassette has a slit size of 3.5" x 3 rows for business card. Optional cassettes are available. See below to select the proper slitter and program for your application.

Slitters

Slitters	Slit Size	Gutter Size	Number of rows	Default Size
Standard Slitter	3.5"	0.25"	3	3.5"
Optional Slitter A	8.5" to 11"	None	1	11"
Optional Slitter B	4" to 6"	0.25"	2	6"

Applications

Layouts	Job #	Applications	Display	Paper Size	Finished W x L	Layouts	Gutter	Margin	Slitters
A	1	Full Bleed Business Cards	Business Card	12"X18"	3.5" x 2"	24 up	0.2 in (5.08 mm)	0.35" (8.9 mm)	Standard Slitter
B	2	Business card	Business Card	12"X17"	3.5" x 2"	24 up	None	0.75" (19.1 mm)	Standard Slitter
C	3	Brochure	Brochure	12"X18"	11" x 8.5"	2 up	0.25 in (6.35 mm)	0.5" (12.7 mm)	Option Slitter A (11 in.)
D		Insert/Greeting Cards		12"X18"	3.5" x 8.5"	6 up	0.25 in (6.35 mm)	0.5" (12.7 mm)	Standard Slitter
E	4	Photo	Photo	12"X18"	10" x 8"	2 up	1.25 in (31.75 mm)	0.5" (12.7 mm)	Option Slitter A (10 in.)
F		Insert/Greeting Cards		12"X18"	3.5" x 8"	6 up	1.25 in (31.75 mm)	0.5" (12.7 mm)	Standard Slitter
G	5	Postcard	Postcard	12"X18"	8.5" x 5.5"	4 up	0.375 in (9.525 mm)	0.5" (12.7 mm)	Option Slitter A (8.5 in.)
H	6	Postcard	Postcard	12"X18"	5" x 7"	4 up	3.25 in (82.55 mm)	0.5" (12.7 mm)	Option Slitter B (5 in.)
I	7	Postcard/Photo	Postcard	13"X19"	6" x 4"	8 up	0.5 in (12.7 mm)	0.5" (12.7 mm)	Option Slitter B (6 in.)
J	8-13 Custom Program	Postcard	(Program)	12"x18"	3.5"x5"	9 up	0.875 in (22.2 mm)	1.00" (25.4 mm)	Standard Slitter
K		Brochure		12"X18"	11" x 17"	1 up	None	0.75" (19.1 mm)	Option Slitter A (11 in.)
L		Postcard		13"X19"	6" x 9"	4 up	0.25 in (6.35 mm)	0.5" (12.7 mm)	Option Slitter B (6 in.)

Optional Slitters

P/N	Slitters Width	Finished Size Length	Slitting Gutter	Remarks
Standard				
882-112-010B	- 3.5"	2"	1/4"	24 Up
Option:				
882-112-010E	- 2"	3.5"	1/4"	25 Up
882-112-020A	- 8.5~11"	8.5~11"	1/4"	2 Up
882-112-030A	- 5~6"	5~6"	1/4"	4~8 Up
882-112-040A	- Scoring			
882-112-050A	- Perforation			

Job Layout

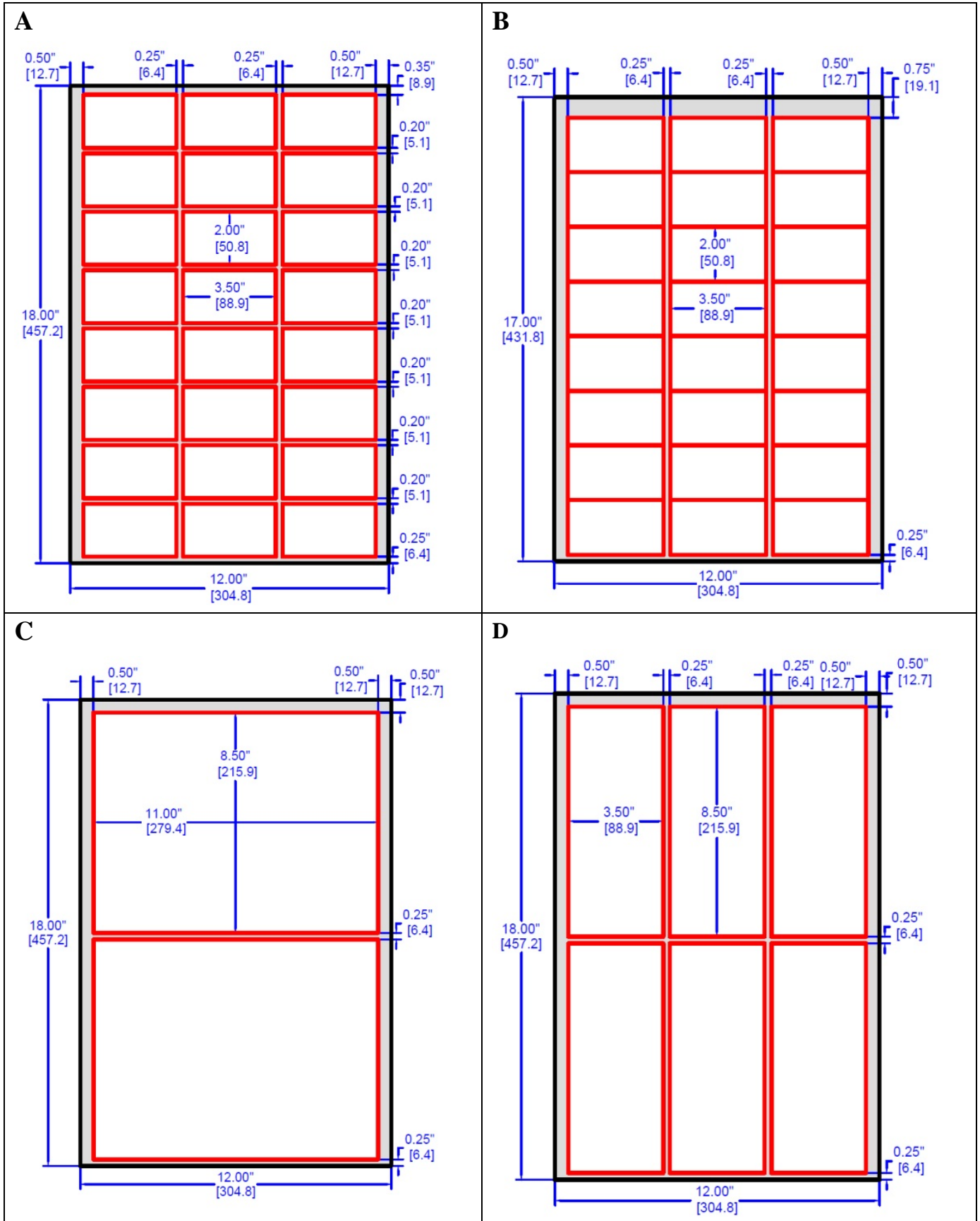

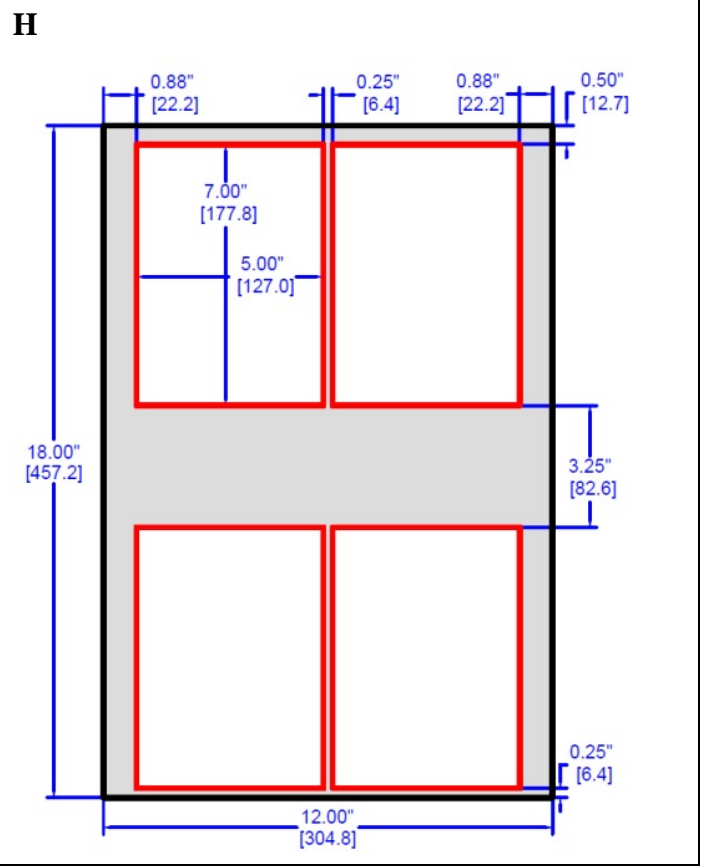
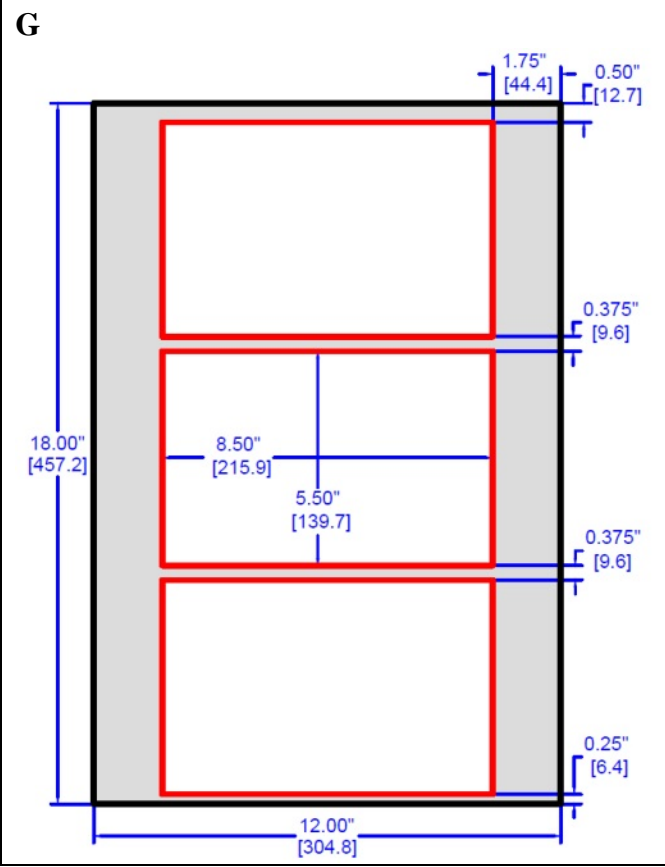
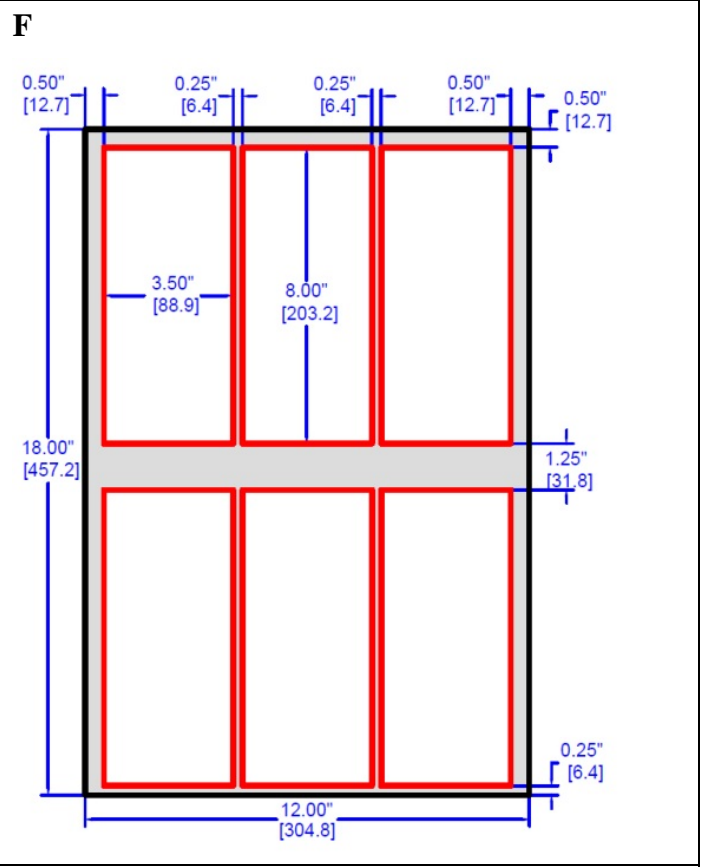
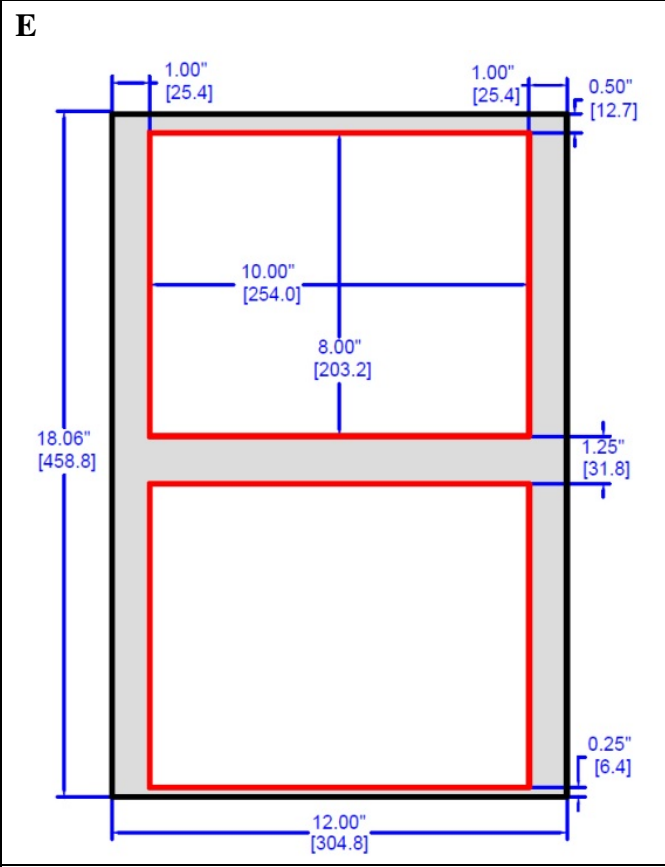

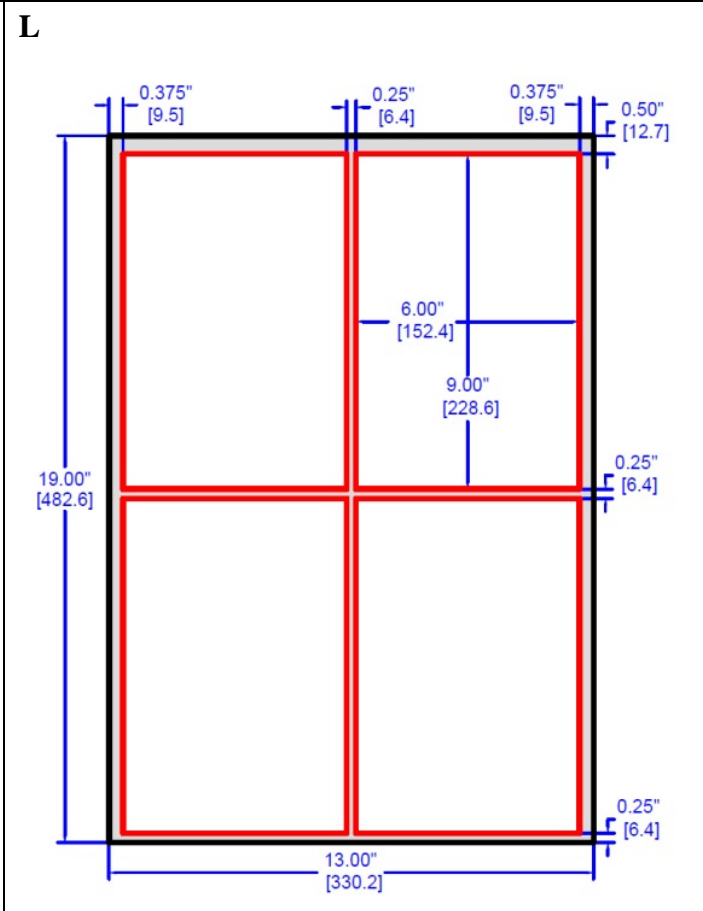
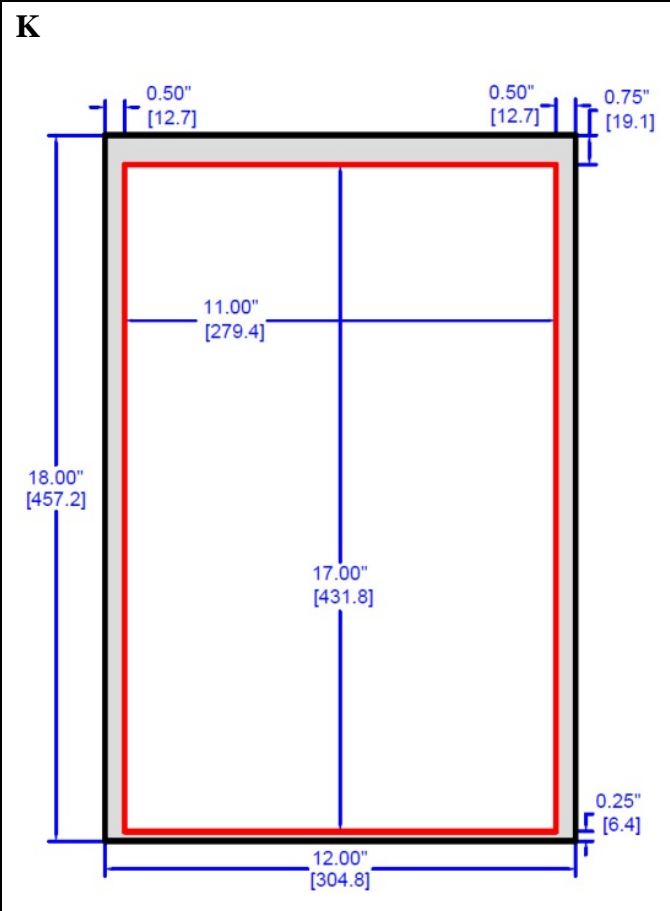
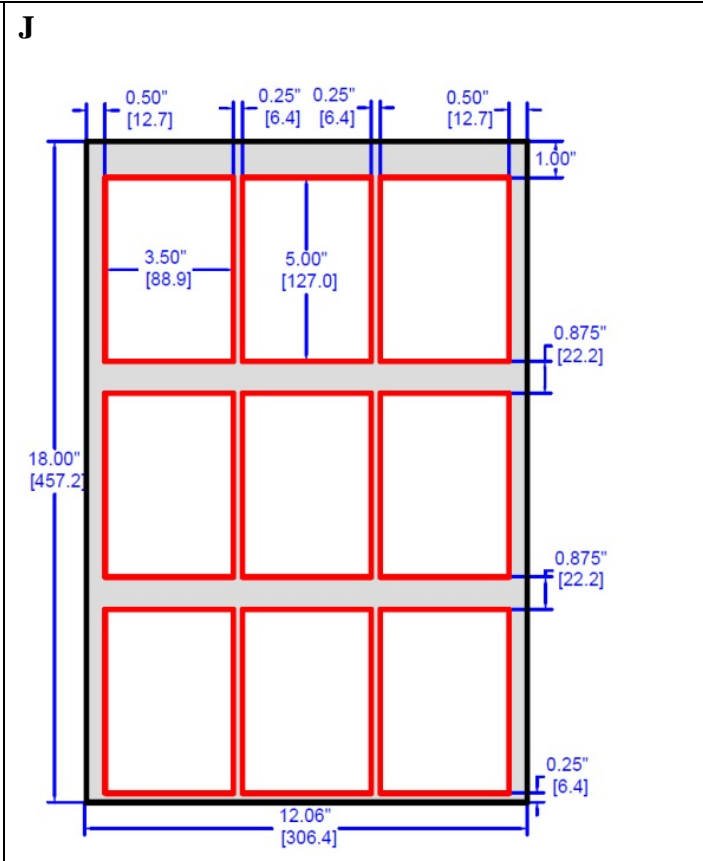
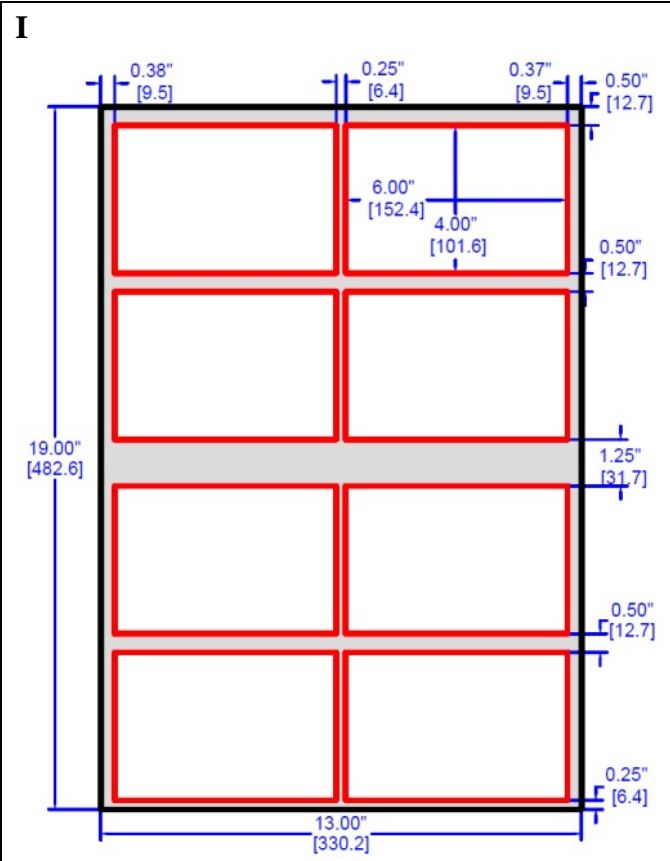



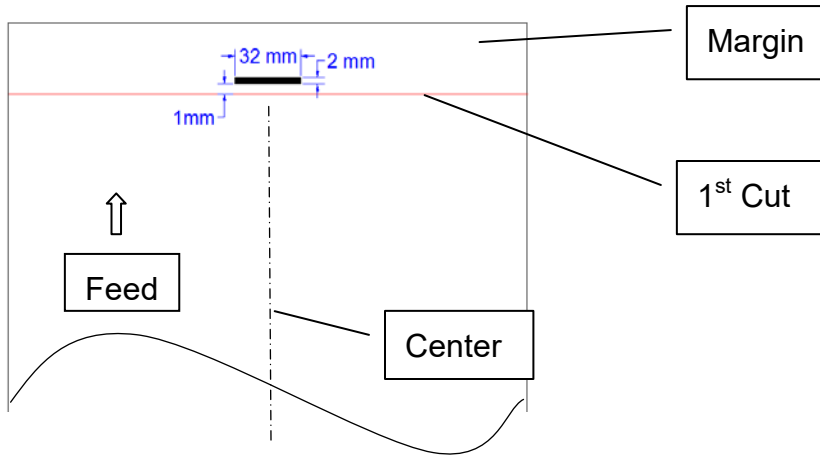

REGISTRATION MARK POSITION

Registration mark will compensate for print shifting. See below for registration mark position.







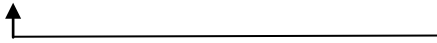

SELECTING A JOB

	Actions	Display Example
1	Turn on the power. Previous job will appear.	<div style="border: 2px solid black; padding: 5px; width: fit-content; margin: auto;"> #01BUSINESS CARD NM 2"x3.5" W/G 23 </div>
2	Press  until the desired job is displayed. 01 → 02 → 03 → 04 ... 13 	<div style="border: 2px solid black; padding: 5px; width: fit-content; margin: auto;"> #04 PHOTO NM 8"x10 W/G 23 </div>
3	Press  to select job	<div style="border: 2px solid black; padding: 5px; width: fit-content; margin: auto;"> #04 PHOTO NM 8"x10 W/G 23 </div>
4	Press  to start operation.	<div style="border: 2px solid black; padding: 5px; width: fit-content; margin: auto;"> #04 PHOTO NM 8"x10 W/G 23 </div>







BATCH COUNT FUNCTION

Batch count function is used to automatically stop the machine after a set # of sheets has been fed.

	Actions	Display Example
1	Press  until the desired batch count number appears. The batch count will increment by 10 every time the button is pressed. Set "OFF" no batch count. Batch → 10 → 20 → 30 → 40 → 50 	
2	Press  to select batch count.	
3	Press  to start operation.	

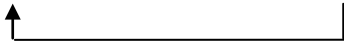

USER DEFINED JOB

Only jobs#8 – 13 can be programmed.

	Actions	Display Examples
1	Turn on the power. Previous job will appear.	
2	Press  until the desired job is displayed. 01 → 02 → 03 → 04 ... 13 	
3	Press  to select job.	



4	Hold  for 4 seconds. "Edit" will appear indicating machine is in "Program Mode".	<div style="border: 3px double black; padding: 5px; text-align: center;">#10L000.0M00.0G00.0 ED 89</div>
5	Hold  and press  to increase or  to decrease change finished length in mm.	<div style="border: 3px double black; padding: 5px; text-align: center;">#10L127.0M00.0G00.0 ED 89</div>
6	Hold  and press  to increase or  to decrease top margin in mm	<div style="border: 3px double black; padding: 5px; text-align: center;">#10L127.0M12.7G00.0 ED 89</div>
7	Hold  and press  to increment or  to decrement change gutter length in mm	<div style="border: 3px double black; padding: 5px; text-align: center;">#10L127.0M12.7G06.0 ED 89</div>
8	Press  to save settings.	<div style="border: 3px double black; padding: 5px; text-align: center;">#10L127.0M12.7G06.0 NM 89</div>

TURBO MODE AND NORMAL MODE

1. Hold  for 4 seconds.
2. Press  to select "Normal Mode" or "Turbo Mode (Default)".
3. Press  to save settings.

PAPER WEIGHT

Adjust paper weight settings if paper is skewing or misfeed. Set 1 or 2 for lighter paper and 4 or 5 for heavier paper.

1. Hold  for 4 seconds.
2. Press  to select settings 1-5. Use table below for references.
3. Press  to save settings.



Setting	Paper Weight
1, 2	120 – 210 (gsm)
3	211 – 300 (gsm)
4, 5	300 (gsm) (Normal Mode)

RESET COUNTER

Hold  and  simultaneously to reset counter to 0.

CLEAR JAM

In case jam occurs in the machine follow these steps to clear jam.



1. Press  and pull out jam paper toward feeding tray.
2. If necessary, depending on location of jam, open the corresponding cover or covers.
If jam persists, refer to **“Error Message and Trouble Shooting”**.
3. After clearing the jams, press  to clear all errors.

. Pure Dark Image “Top Margin” Adjustment



Pure dark image on whole image such as black, grey, green, blue...etc without 0.5” white boundary will cause top margin cutting variance due to sensitivity differential. Recommend to do “Top Margin” calibration.



The calibration allows calibrate procedure as below:

On job #4 to hold  then press  to set cutting mark, Cut a printed sheet with mark. Make sure the leading edge of the mark to cutting line is 3mm

Select mark:50, if the cut mark leading edge to cutting line is greater or smaller than 3mm, press

 and  to adjust. Each press represents 0.1mm increment or decrement.

After adjusting the mark value, press  to save the setting. Cut the mark again. If the cut mark is not within spec. repeat the calibration.

. Paper Weight Greater than 300gsm

1. Set the feed tray tension index smaller than 3



2. Set paper weight to 5

Refer to page 18, paper weight setting

3. Squeeze down the compression spring on first set of transport roller preventing slippage.

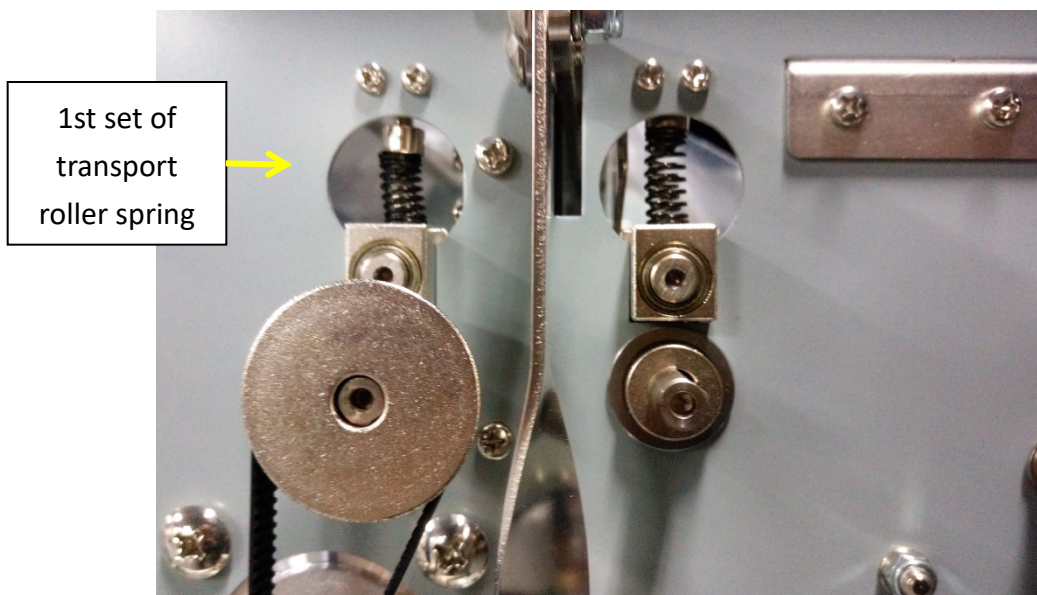

TROUBLESHOOTING

Error	Troubleshooting
Out of paper	Feed tray empty
misfeed	<ol style="list-style-type: none">1. Adjust the feed tray tension2. Side guide too tight. Adjust side guide.3. Fan the paper and reload into hopper
jam sensor 2	<ol style="list-style-type: none">1. Remove the paper jam by pulling toward stacking tray.2. Adjust the feed hopper tension, if double feed happens
jam sensor 3	<ol style="list-style-type: none">1. Use JOG key to clear the jam2. Adjust feed hopper tension, if double feed happens
check top cover	Put the top cover in position
check rear cover	Put the rear cover in position
Finished card not clean and neat	Call for service
Error message cannot reset	Check covers and paper jam

INSTALLATION OF OPTIONAL SLITTER

Optional slitters enable the FD125 to have more range of applications. Follow the steps below to the replace optional slitter cassette.

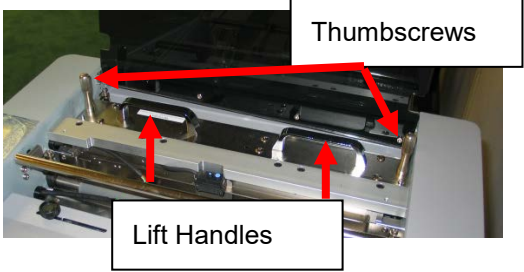





1. Lift Top Cover	
2. Remove thumbscrew by turning counter-clockwise on both side of the slitter cassette.	
3. Using both hands, lift the slitter cassette.	
4. Replace with the desired slitter cassette.	
5. Secure the slitter cassette with the thumbscrew by turning them clockwise.	

OPTIONAL CONVEYOR

Items List

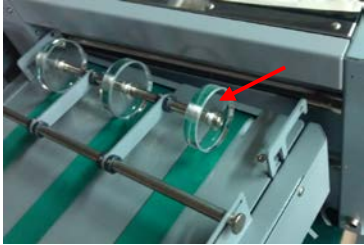
		
1 x Conveyor	1 x Ramp	1 x Pick-Up Rollers Assembly
		
1 x Interface Cable	1 x Stand Support	4 x Studs
		
4 x Socket Cap Screws (M6x12)	4 X Shoulder Washers	2 x Spacer
		
4 x Machine Screws (M4 x 12)	2 x Machine Screws (M5 x 35)	2 Thumbscrews (M4 x 12)
		
5 X Machine Screw (M5 x 10)	5 x Washers (M5)	

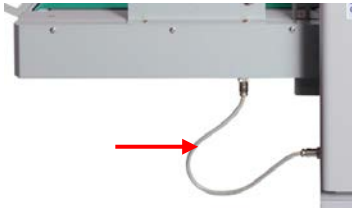
Installation Procedure

<ol style="list-style-type: none">1. Remove the side covers.2. Remove the safety guard	
<ol style="list-style-type: none">3. Install the 4 studs as shown using Socket 4 Cap Screws (M6x12) and 4 Lock Washers (M6).	
<ol style="list-style-type: none">4. Hook the conveyor onto the studs.	
<ol style="list-style-type: none">5. Use 2 spacers and Machine Screws (M5 x 35) to secure the conveyor on the left and right side located below the conveyor.	
<ol style="list-style-type: none">6. Plug interface cable to conveyor and machine.	
<ol style="list-style-type: none">7. Install the ramp using the key holes.	

8. Install Pick-Up Roller assembly using 2 thumbscrews as shown onto conveyor rails. Adjust roller distance depending on paper finish size for better stacking.



9. Install stand support using 5 x (M5 x 10) screw and washer to secure stand support to the conveyor

