

FORMAX[®]

Atlas C100
Auto-Feed High-Speed Creaser

INDEX

INTRODUCTION	
The Atlas C100	PAGE 3
SAFETY Do's & Don'ts	4
Labeled Photograph	6
THE CONTROLS	7
The switch panel	7
Features on the switch panel	8
QUICK START GUIDE	9
OPERATING	
Setting the machine	18
Programming the machine	22
Reading stored programmes	23
Paper jamming	25
THE STACKER ASSEMBLY	
Setting the Stacker unit	26
PERFORATING	
Equipment, spares	28
Setting the machine	29
THE BLADE ASSEMBLY	
Setting the blade pressure	31
Setting the blade alignment	32
REPLACING CREASING BLADE SETS	
Installing new blade sets	33
Spares	34
TROUBLE SHOOTING	35
DISPATCH KIT	40
ACCESSORIES & OPTIONS	41
RECOMMENDED SPARES	42
FUSE POSITIONS AND RATINGS	44
PRODUCT RECYCLING & DISPOSAL	45

INTRODUCTION

The Atlas C100 is a fully automatic suction feeding creasing system designed for use with both conventional litho and digital printers.

The feed on the Atlas C100 can also be manually operated for use with heavy stock, very small or very large sheets, embossed or even irregular sheets.

The crease is programmed from the leading edge of the sheet using the controls on the front panel.

The blade and anvil are mechanically controlled over their entire length and can be adjusted to accommodate various weights of media.

IMPORTANT

The operating environment should be controlled to a temperature between 16° C and 27° C Maximum

Specification

Feeding System	Bottom suction feed
Max. Sheet Size	700mm x 330mm (27.5" x 12.6")
Min. Sheet Size (in automatic mode).....	210mm x 140mm (8.5" x 5.5")
Max. Paper Thickness	0.4mm (varies according to hardness, type of fold, and substrate)
Max. No. Creases per Sheet	16
Min. Distance Between Creases	0.1mm
Max. No. Stored Programmes	Unlimited
Min. Crease Distance from Leading Edge	2.5mm
Min. Crease Distance from Tail Edge	35mm
In Hand Feed Mode up to 2499.9mm to Last Crease can be Programmed.	
Speed per Hour (A4 in half).....	8500
Speed per Hour (A5 in half).....	11000
Dimensions	L: 1450mm H: 1224mm W: 522mm L: (57") H: (48.2") W: (20.5")
Weight	121Kgs (+50Kgs packing)
Power Requirement	1 phase 220 / 240v AC

*As part of our continued product improvement plan, specifications and information published in this manual are subject to change without notice.

All specifications are dependant on application, type of stock, temperature, RH and print engine used.

Specifications quoted were measured on uncoated and unprinted stock.

E & OE.

Safety Do's & Don'ts

Safety Do's & Don'ts

REGLES DE SECURITE : « A FAIRE » ET « A NE PAS FAIRE »

- Do - read this operator manual fully before operating the machine.**
Lire ce mode d'emploi avant d'utiliser la machine.
- Do - operate with the designated AC current only. Use an exclusive outlet, as overloading may cause fire or an electric shock.**
Respecter l'alimentation électrique indiquée. Brancher sur une prise séparée car une surcharge peut entraîner un incendie ou un choc électrique.
- Do - install the power cord out of the way to avoid a tripping hazard.**
Installer le cordon d'alimentation de manière à ne pas pouvoir trébucher par dessus.
- Do - make sure that the mains inlet connector is always easily accessible.**
Ménager un accès libre à la prise de courant.
- Do not - install the machine in an unstable place such that it tilts or shakes.**
Ne pas installer la machine sur une surface non plane, afin d'éviter qu'elle ne penche ou ne vibre.
- Do not - unplug the plug or unplug the power cord from the outlet with a wet hand, this can cause an electric shock.**
Ne pas installer la machine sur une surface non plane, afin d'éviter qu'elle ne penche ou ne vibre.
- Do not - unscrew and remove any covers from the machine, as it can cause an electric shock or injury.**
Ne démonter et enlever aucun carter de la machine, par crainte de décharge électrique ou de blessure.
- Do not - place receptacles containing liquids on any surface.**
Ne pas placer de récipient contenant un liquide sur la machine.
- Do not - adjust any part of the machine whilst rollers are running**
N'effectuer aucun réglage pendant que les rouleaux fonctionnent.
- Do not - operate the machine with loose or trailing clothing or loose hair.**
Ne pas porter de vêtements flottants et rassembler les cheveux longs lors de l'utilisation de la machine.
- Do not - under any circumstances adjust the paper gate when the machine is switched on.**
En aucune circonstance, régler le séparateur de papier lorsque la machine est branchée.

Warning Labels



Do - be aware of any finger traps and rotating parts when operating the machine.

Attention au risque de se coincer les doigts, et aux pièces en mouvement lors du fonctionnement de la machine.

Do - read this operator manual fully before operating the machine.

Lire ce mode d'emploi avant d'utiliser la machine.

Do not - operate the machine with loose or trailing clothing.

Ne pas porter de vêtements flottants lors de l'utilisation de la machine

Do not - operate the machine with loose hair.

Rassembler les cheveux longs lors de l'utilisation de la machine.



Do - be aware of any finger traps and rotating parts when operating the machine.

Attention au risque de se coincer les doigts, et aux pièces en mouvement lors du fonctionnement de la machine.

Do - be aware of sharp points and blades.

Attention aux éléments tranchants et aux couteaux.

Do - be aware of rotating rollers.

Attention aux rouleaux en fonctionnement

Do - be aware of low current anti-static shock.

Attention aux faibles chocs d'électricité statique

DOCUMENT CREASING MACHINE

Key to photograph below

- | | | | | | |
|---|-----------------------|----|---------------------|----|--------------|
| 1 | Roller tilt handle | 6 | Air separation knob | 11 | Paper Gate |
| 2 | Stacker assembly | 7 | Adjustable side lay | 12 | Exit Guard |
| 3 | Suction slot knob | 8 | Back stop | 13 | Switch Panel |
| 4 | Touchscreen | 9 | Fixed side lay | 14 | Fuses |
| 5 | Air distribution knob | 10 | Roller tilt knob | | |

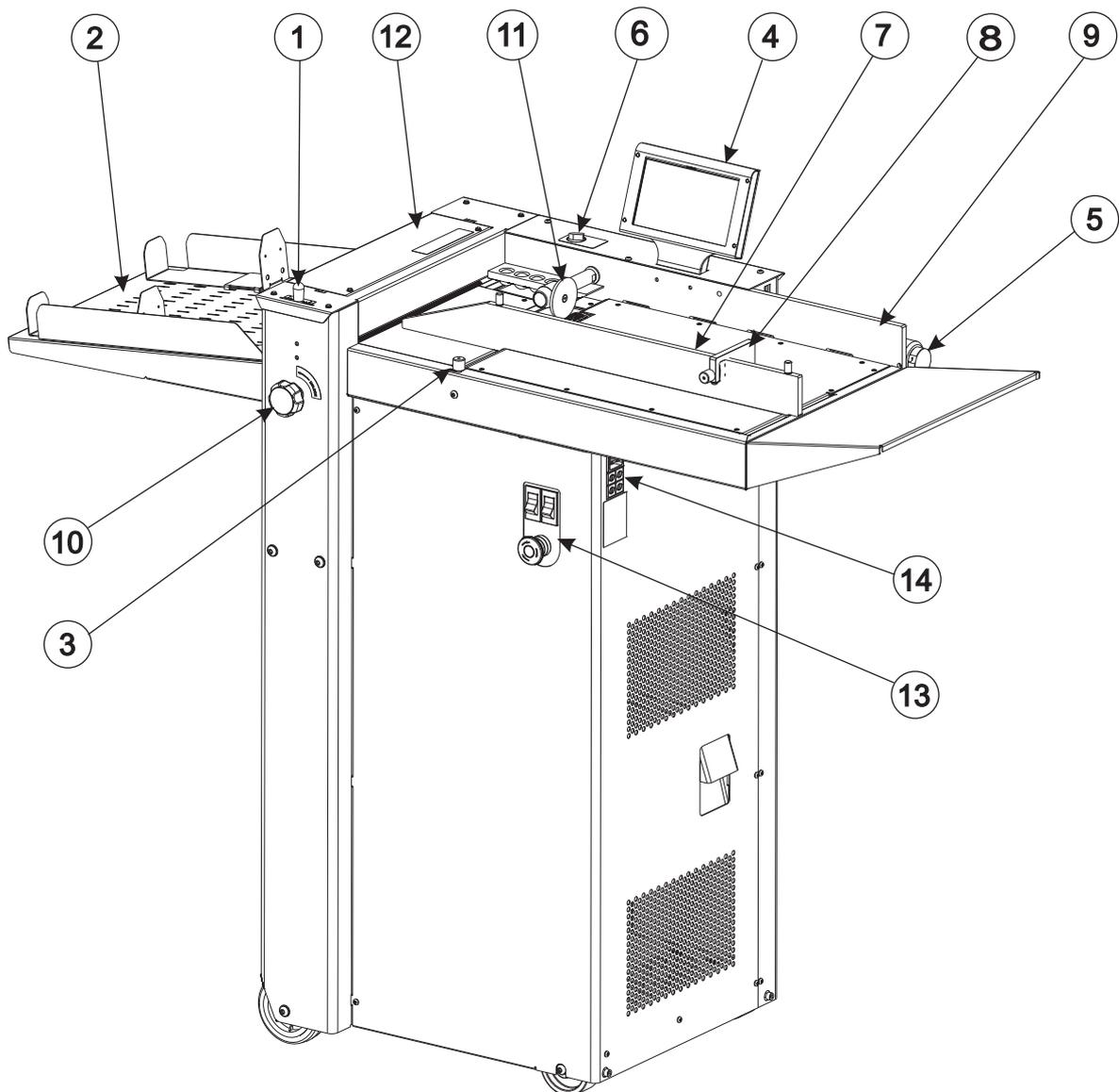

THE CONTROLS

The Switch Panel houses the Compressor switch, System switch, and an industry standard Emergency Stop switch which will stop all power going to the machine when activated.

THE SWITCH PANEL

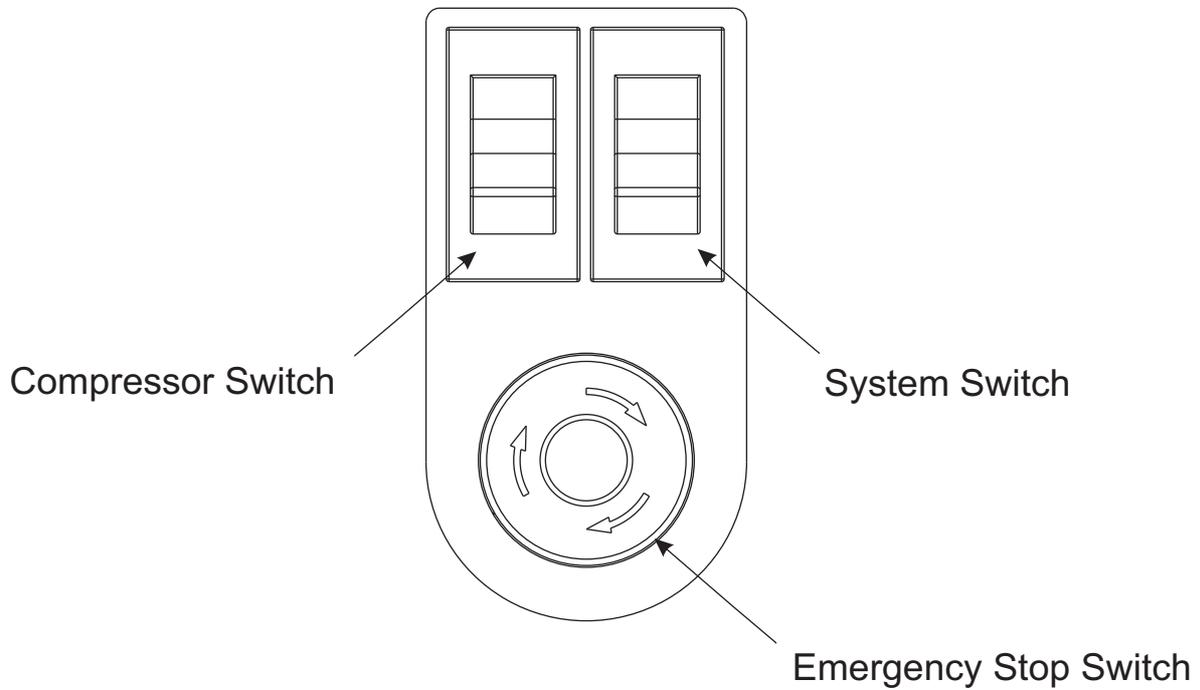

THE CONTROLS

Features on the Switch Panel

System switch

When activated the system switch will operate the motors in order to begin the creasing sequence.

Compressor switch

Allows the operator to switch off the compressor unit in order to utilise the machine to manually feed sheets.

Quick Start Guide

Setting the machine to operate in automatic sheet feed mode

1. Set the gap between the paper gate and the vacuum roller to approximately twice the thickness of the stock to be creased.
2. Place the stock to be creased onto the loading table against the fixed side lay.
3. Release the clamps on the adjustable side lay and slide up to the paper stack allowing a gap of approximately 0.5mm (1/64 inch) between the paper and the side lay.
4. Position the backstop and slide it up to the paper stack, also allowing a gap (as stated in the above step).
5. Turn the Emergency Stop button clockwise to switch the power on. After the system start up procedure the touch screen will be displayed as shown below.



IMPORTANT.

If you have not been trained to operate this machine, we strongly advise that you select the red cross icon.

We recommend that you either seek training or ask a trained operator to run the machine for you.

Select the green tick icon only if you have been trained to operate this machine.

Quick Start Guide

The touch screen is laid out into 3 main areas as shown below:

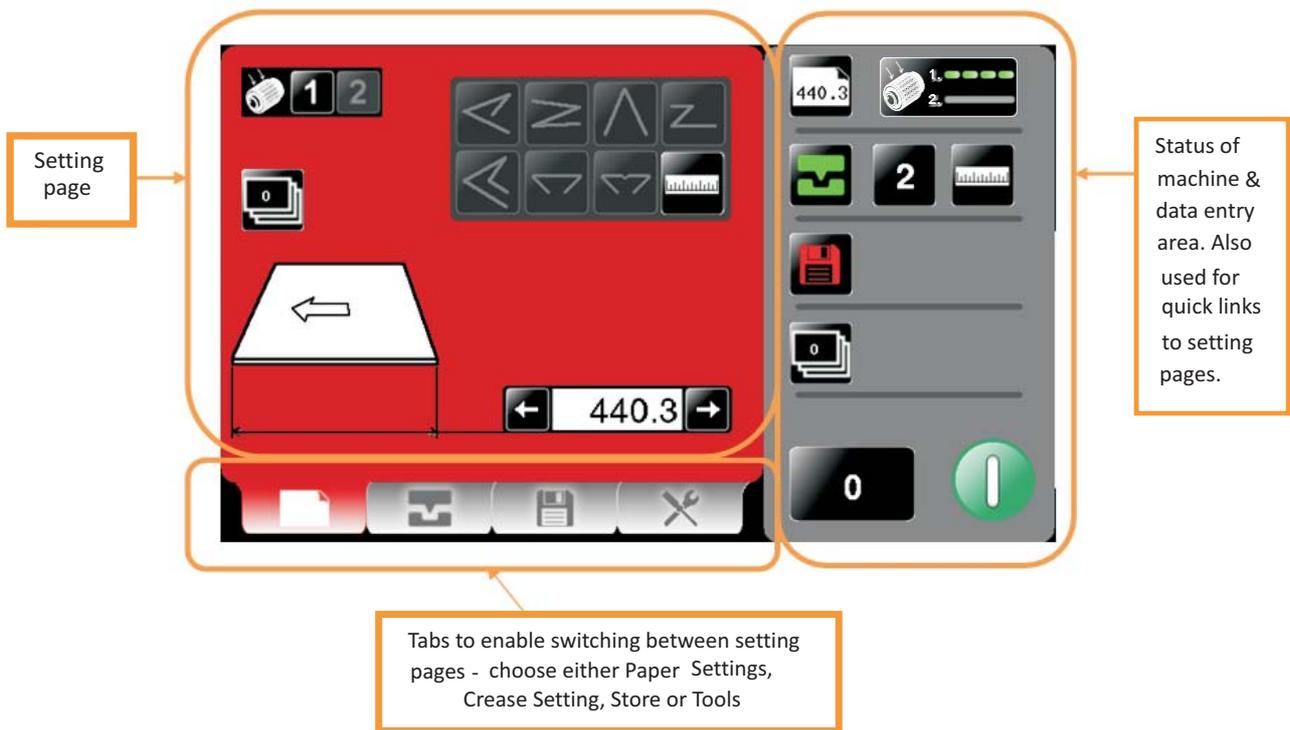

Settings Pages.

Paper Settings Page.

Vacuum Suck - There are two selections available - 1 short suck & 2 continuous for stream feeding. Highlighted number is type currently selected. The status area also shows currently selected suck.

Batch Button - Image is identical to that shown in the status area. On selection the status area is replaced with a calculator for inputting new values. Batches of any numerical value.

Fold Selection - For quick setting of crease positions on standard size sheets. Highlighted fold is type currently selected, other folds may be selected. Currently selected fold is shown in the status area.

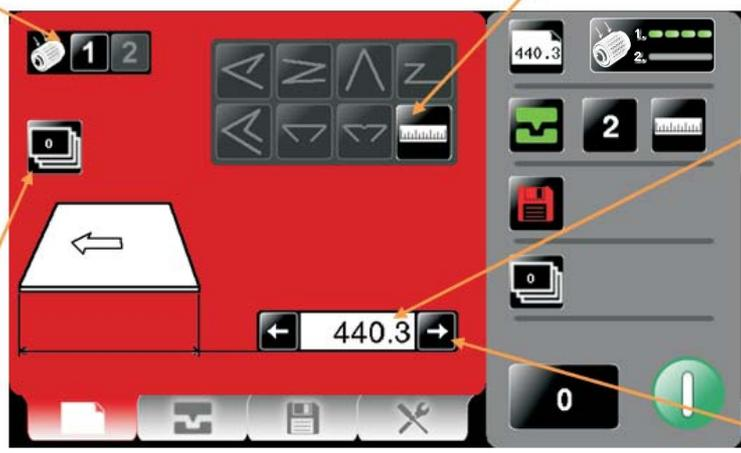

Page Length - On selection the status area is replaced with a calculator for inputting new values. Min Length = 190mm

Arrows may be selected to increase or decrease the page size in 0.1mm increments

Quick Start Guide

Crease settings Pages.

To get to the crease setting page click the lower tab  or  from the status area.

If you have selected a predefined standard crease type from the paper settings page the crease positions will be set for you. These positions can be fine tuned by ± 0.1 mm increments by pressing side arrow buttons   for each crease.

Number of creases – if more than 6 creases are added a scroll bar will appear for to enable viewing of all creases

Crease position - On selection the status area is replaced with a calculator for inputting new values.

Cross box for deletion of crease. On deletion of crease following creases will move up by one place. You will be asked to confirm deletion of the crease.

Press to remove all creases – you will be asked to confirm deletion.

Arrows may be selected to increase or decrease the page size in 0.1mm increments

Plus box for inserting additional creases. On selection following creases will move down by one place a maximum number of 6 creases can be seen at any one time further creases can be accessed by use of the scroll bar.

Scroll bar - use to bring required crease into view.

Crease on/off selector green is on & red is off. This is also indicated in the status area.

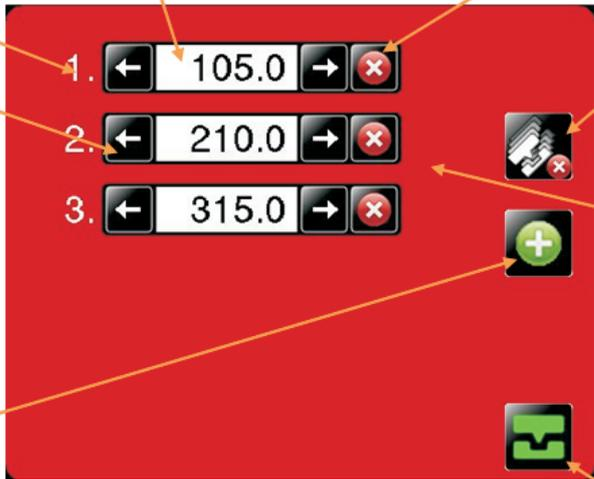

The screenshot shows a red interface with three crease settings: 1. 105.0, 2. 210.0, and 3. 315.0. Each setting has left and right arrow buttons and a red 'X' delete button. A green '+' button is at the bottom right. A green crease icon is at the bottom center. A scroll bar is visible on the right side.

Additional creases added – scroll bar appears for more than six creases.



The screenshot shows a red interface with six crease settings: 1. 102.5, 2. 132.5, 3. 155.0, 4. 202.0, 5. 220.0, and 6. 260.0. A vertical scroll bar is present on the right side of the crease list. The interface also includes a green '+' button, a green crease icon, and a status area on the right with various icons and a green indicator.

Quick Start Guide

Individual deletion of crease confirmation screen

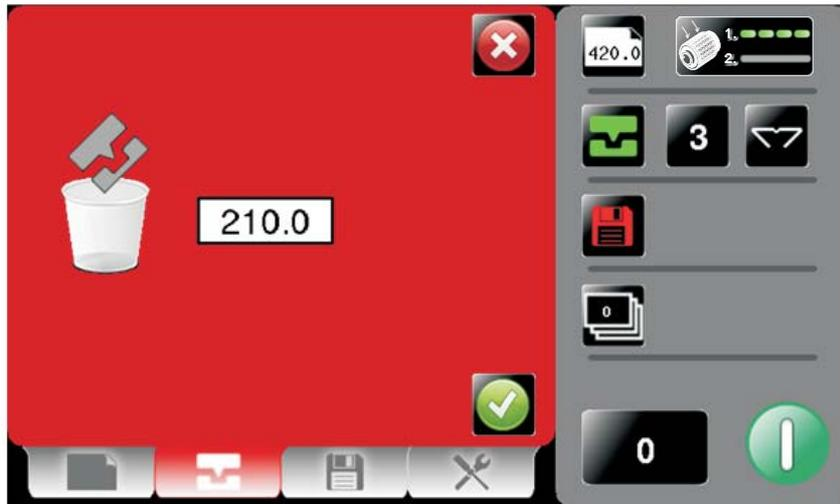

Select green tick icon to confirm deletion of crease.

Remove all creases confirmation screen.

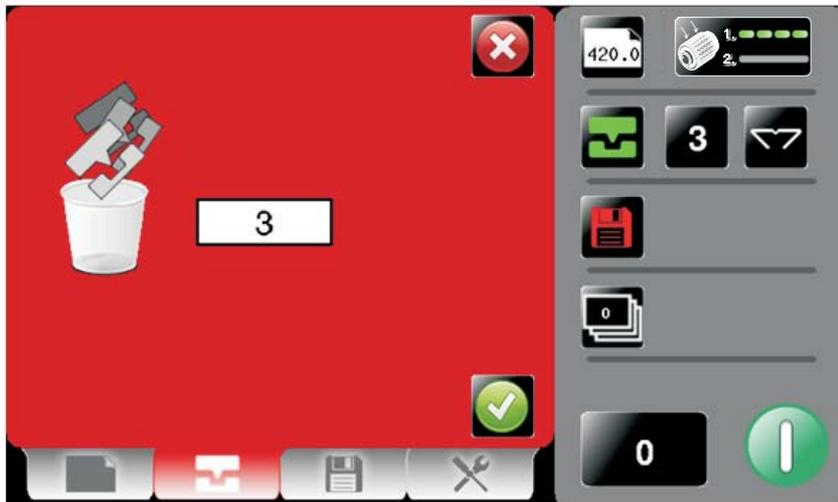

Turn Crease on/off.

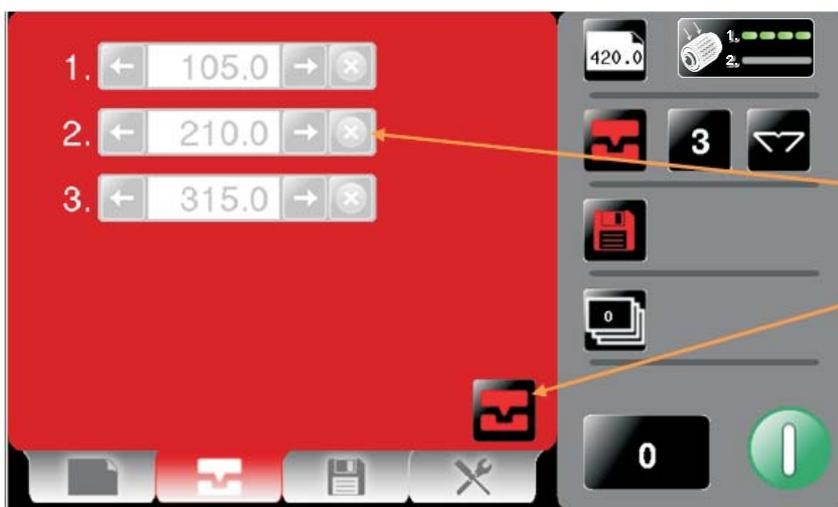

Creasing turned off -
Greyed out areas are
unselectable. Status
area will show
creasing is off with
red icon

Run Job

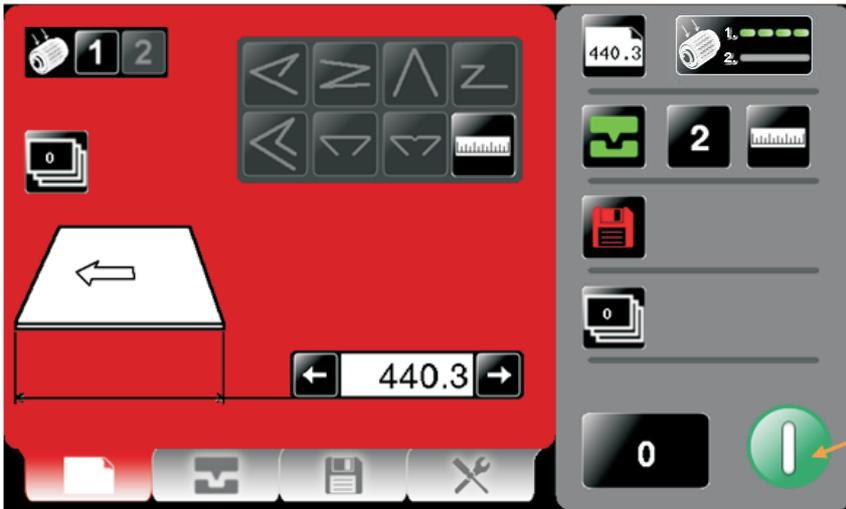

Click to start machine with settings currently shown - you will receive a notification if system switch is not on. Press again to stop Job

System Switch Not On

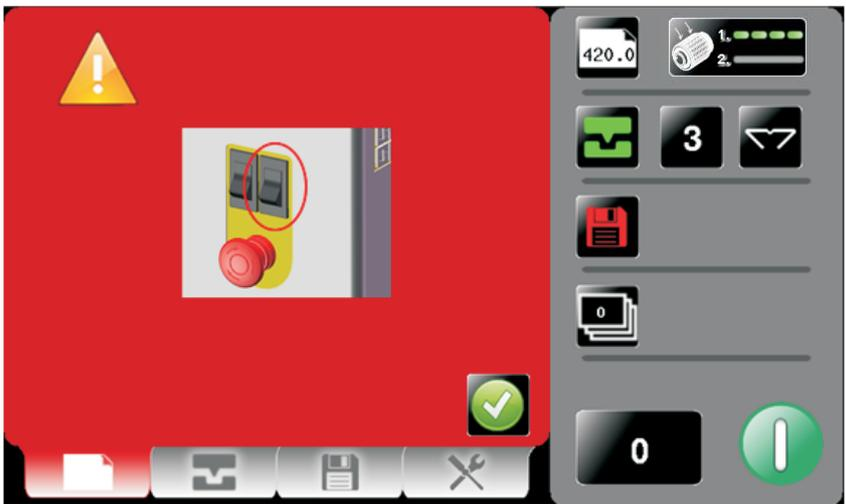

Push System Switch down to start the machine.

The machine running screen will appear.

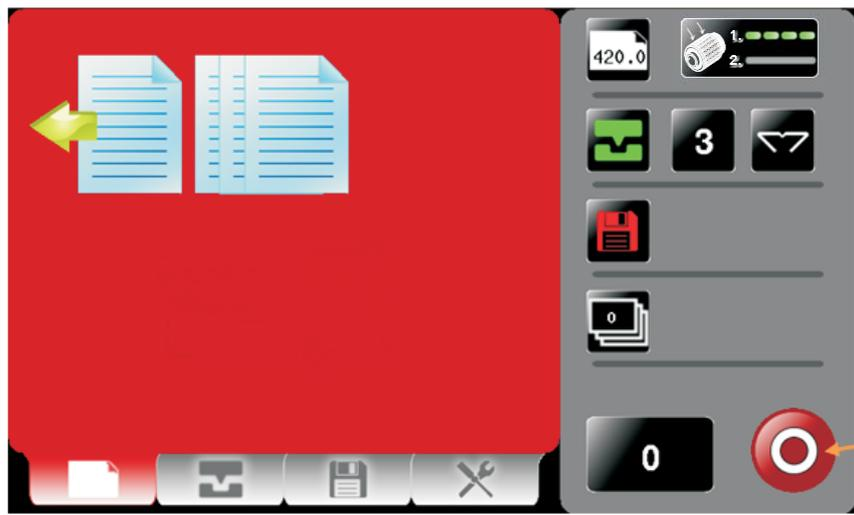

Click to stop machine

Quick Start Guide

Status Screen

Paper length - input from the paper setting screen

Clicking in this area will take you to the paper setting page

Currently selected Vacuum Suck setting - for stream setting choose selection 2

Number of creases - this may alter automatically if a pre - defined fold is selected. Adjustments may be made in the crease setting screen



Currently selected fold type - can be one of the following.



Green icon indicates settings are saved - a red icon would show that settings have been changed but the job has not been saved.

Clicking in this area will take you to the Crease setting page

Batch quantity - this is input from the batch calculator on the paper setting screen - max. 999

Clicking in this area will take you to the Job Store page

Current Job count - click to zero

 A screen will appear to confirm that you want to reset the count.

Clicking in this area will take you to the paper setting page.

Click to start machine with settings currently shown - you will receive a notification if system switch is not on. Press again to stop Job

Quick Start Guide

The Status Screen will on occasions be replaced with an Input Calculator Screen as shown below.

Pre - set Paper sizes for quick insertion – Standard sizes for country origin would be shown



Paper size
input calculator

Pre - set Batch sizes for quick insertion.



Batch size
input calculator



Crease position
input calculator

NOTE:

The green tick or the red cross must be selected on the Calculator Screen to make the left hand side of the touchscreen active again.

Quick Start Guide

Tools Screen

Machine Speed Adjustment:-
Speed setting 3 will give the fastest throughput of stock through the machine.
Use speed setting 1 or 2 for troublesome stocks, or to synchronise the speed of the AutoCreaser to a Morgana Autofold Pro, when they are used together.

Inch paper in direction of arrow to clear jams

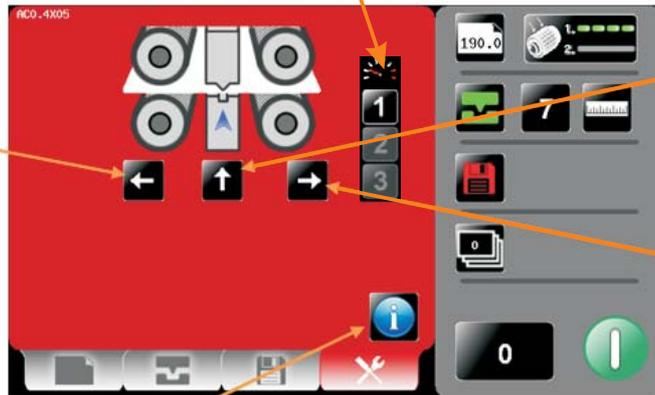

Click on Up Arrow to put Anvil into Top Dead Centre position (TDC)

Inch paper in direction of arrow to clear jams

Clicking this icon will show Machine program revision & Touch Screen software revision.

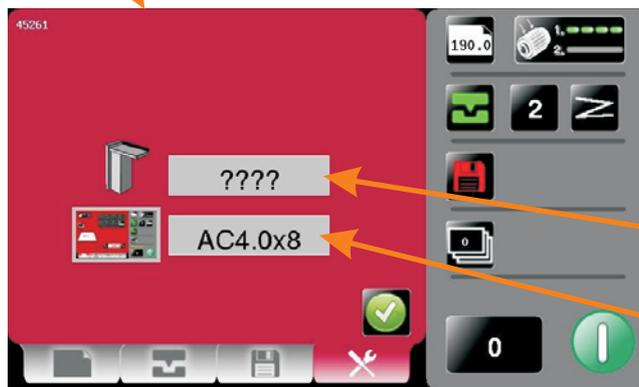

Main Processor Program version

Touch screen software version

BLANK
PAGE

Setting the Machine

Adjusting the Paper Gate

Set the height of the Paper Gate to approximately two thicknesses of paper, by turning the disc j. An excessive gap is a most likely cause of double sheet feeding.

This setting is only intended as a guide, for instance, sheets with an upward curl will require this setting to be increased.

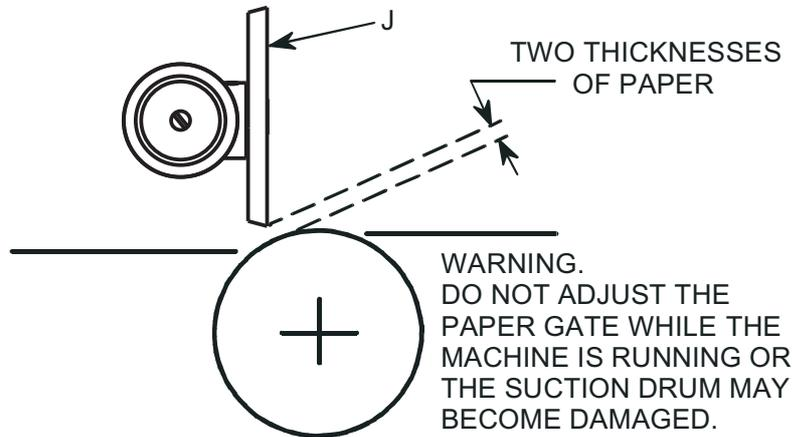

Setting the Suction Slot

The suction slot is located inside the vacuum roller and can be adjusted by releasing and moving the suction knob horizontally in either direction to the required position.

For light stocks set the knob to the left and for heavier stocks set the knob to the right.

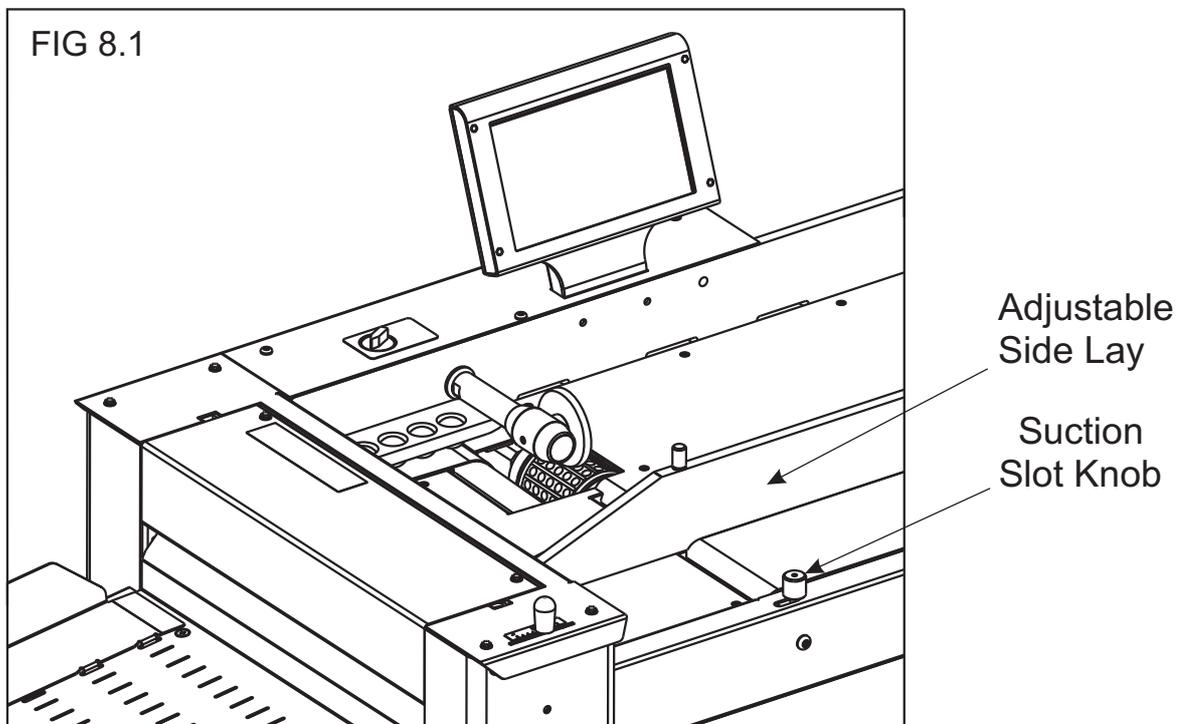

Setting the Adjustable Side Lay

Place the paper stack on to the loading table and slide up to the fixed side lay and paper gate. Release the clamps located at each end of the side lay and slide up towards the paper stack as demonstrated in fig 8.1. Allow a gap of approximately 0.5mm (1/64 inch) between the paper and the side lay.

Setting the Back Stop

Position the backstop and slide up towards the paper stack allowing a gap (as specified in the above step).

Setting the Air Distribution

Depending on the length of the sheet to be creased, the air distribution knob can be rotated to various positions in order to supply air to different ports. Position 2 is recommended for most sheet sizes. However, a better result may be obtained by using the settings below or by experimentation.

- Position 0** - For sheets longer than A3 (17") in order to supply air to the centre of the stack, ports 2 and 3 open.
- 1 - For A5 sheets or 8 inches long, ports 1 and 2 open.
 - 2 - For A4 sheets or 11 inches long, ports 1 and 3 open.
 - 3 - For sheets longer than A3 (17") in order to supply air evenly along the stack, ports 1 and 4 open.

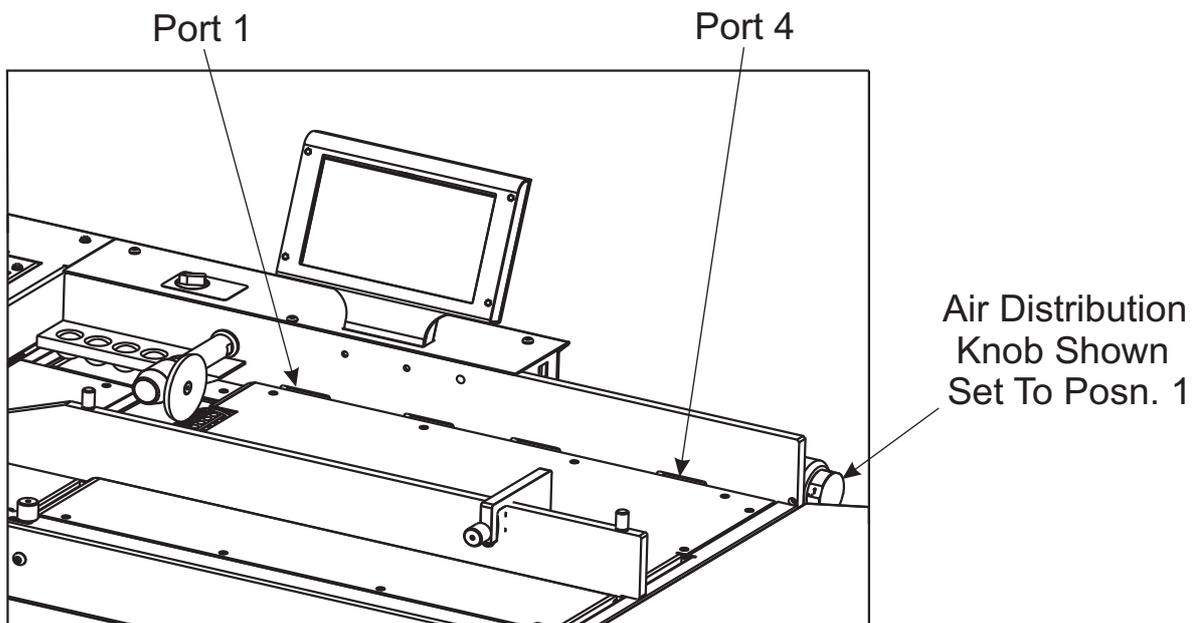

Setting the Air Separation Pressure

To control the amount of air supplied to the ports, the air separation knob can be rotated clockwise to decrease the pressure or anti-clockwise to increase the pressure.

Setting the Roller Tilt Mechanism

The roller tilt mechanism has been designed to compensate for when the creasing position on the sheet is not square. This could be due to an inaccuracy in the media or if the roller tilt mechanism has been incorrectly set. The mechanism will be set to zero (square) when the machine is supplied.

To set the mechanism, unlock the roller tilt knob located below the roller tilting handle by turning anti-clockwise. Move the roller tilt handle left or right in order to compensate for any inaccuracy. When the position is set, ensure to lock the roller tilt knob before operating the machine. Repeat the above procedure until the creasing position is square.

Setting the positions of drive wheels and hubs

It is important that the drive wheels and drive hubs on the roller shafts are arranged evenly across the width of the media being creased. This is done to ensure that the media is accurately driven and supported through the rollers.

The drive wheels and hubs are fixed to the rollers by means of a grub screw. To locate this grub screw the rollers can be rotated by operating the motor manually.

DO NOT ROTATE THE DRIVE ROLLERS BY HAND.

To operate the motors manually, switch the machine 'on' at the Emergency Stop switch.

Select the Tools tab  at the bottom of the touch screen, the display will change to that shown below.



Press the system switch down and then select the right or left arrows, to rotate the rollers in short pulses.

Lift the exit guard to see if the grub screws in the drive wheels and hubs can be seen. If the grub screws cannot be seen, lower the exit guard and rotate the rollers by selecting the right or left arrows. Loosen the drive wheels and hubs with a 2mm allen key. Arrange the drive wheels and hubs as shown in FIG 10.1. In order to avoid marking on some types of media ensure a gap between the drive wheels and hubs.

This procedure should be repeated when installing perforating blades and anvils onto the drive wheels and hubs.

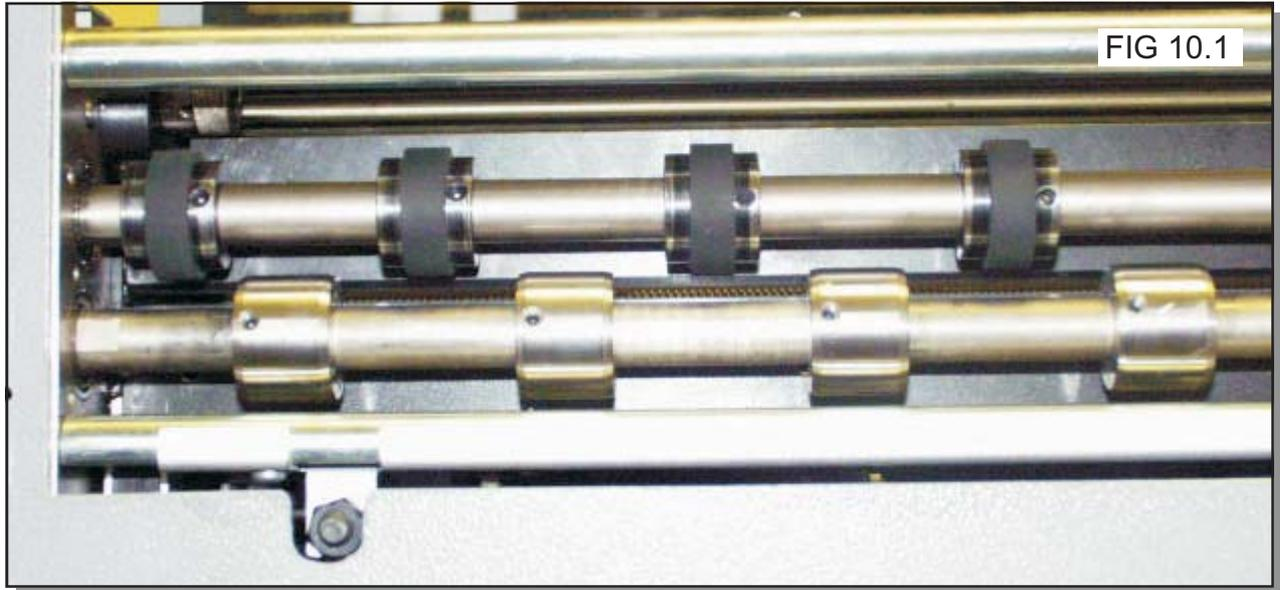

Set Feed

The length of suction on the sheet of paper being fed can be adjusted by setting the feed type as follows:-

Select 1 for short suck, select 2 for continuous suck (stream feeding).

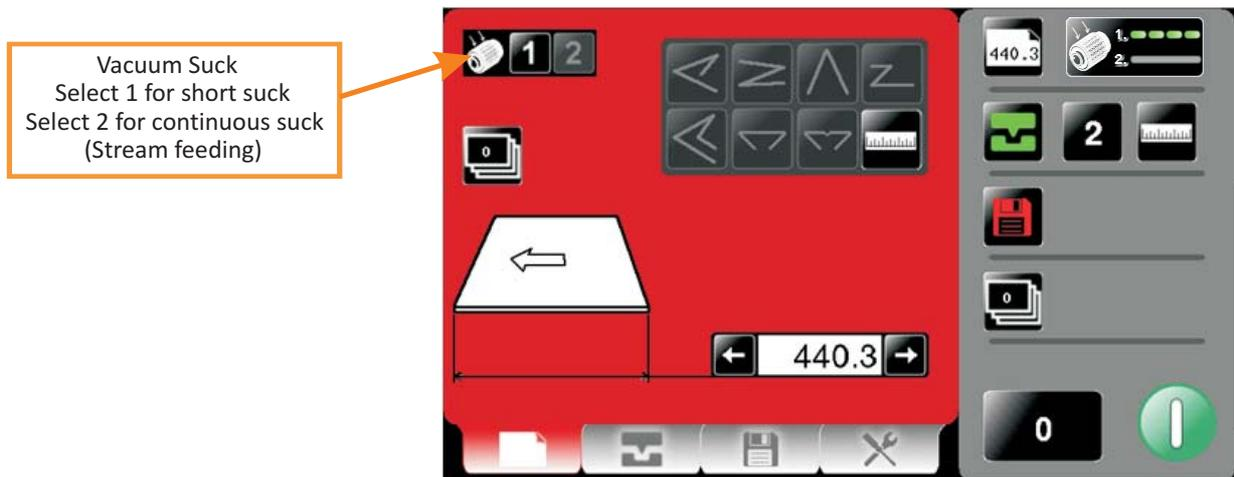

NOTES.

1. **Stream Feed** will give the quickest through put of stock through the machine.
2. When the first crease is less than 37mm from the leading edge of the paper the feed will be noticeably slower.

Programming the machine

1. Switch the power 'on' by turning the Emergency stop button clockwise to release the safety latch.

Setting the page length

2. Set the page length of the paper as described on page 10.

Setting the vacuum suck

3. Set the vacuum suck as described on page 10. Setting number 1 for short suck and setting number 2 for continuous suck (stream feed).

Setting the batch quantity

4. Select the  button. On selection the status area is replaced with a calculator for inputting new values.

Setting the crease positions

5. (i) Select the lower tab  or  from the status area to get to the Crease Settings Page.
(ii) Set the creases as described on pages 11 and 12.

Storing the Job

6. The job that has been set can now be stored as follows.

- (i) Select the lower tab  or  from the status area to get to the Store Settings Page.
- (ii) The job can be given a name and stored as described below. You can also retrieve previously saved jobs, modify them or delete jobs that are no longer required.

To create a new job name click in text area & keyboard will open to input job name.

Load existing job from store



Clicking to search currently stored jobs

Clicking to delete currently stored jobs

Clicking to save job shown.

Keyboard for entering job name.



Return to Store Menu & click save icon  to save job to store

Save confirmation screen.



To confirm saving of Job click here.

Search for current jobs to load or modify.

You can search for jobs by clicking the search icon  , this will bring up the search keyboard for text input.



Type in job description or first few characters

Press search icon to start search

To change your mind & return to the previous screen click here.

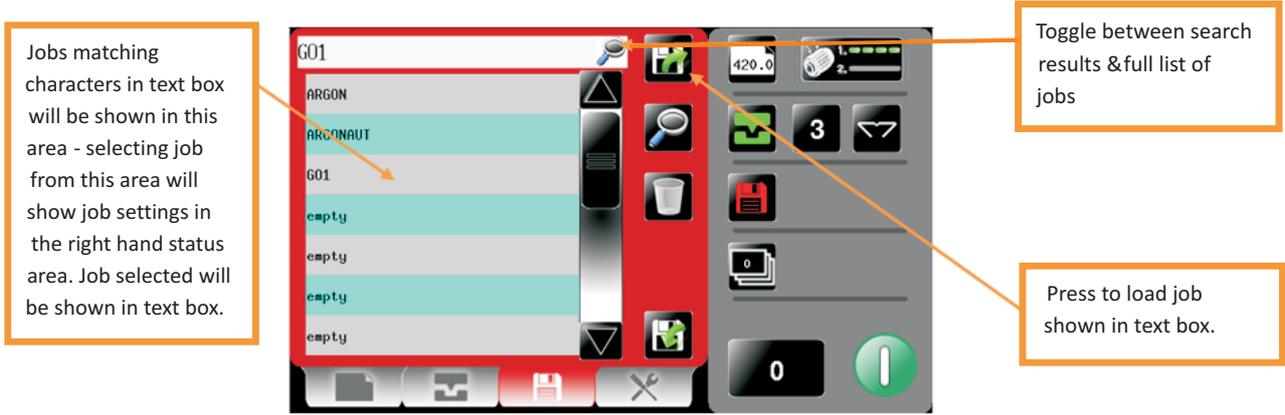

Loading job confirmation screen.



The loaded job can be run or modified and saved as the same job name.

Overwrite job confirmation screen.

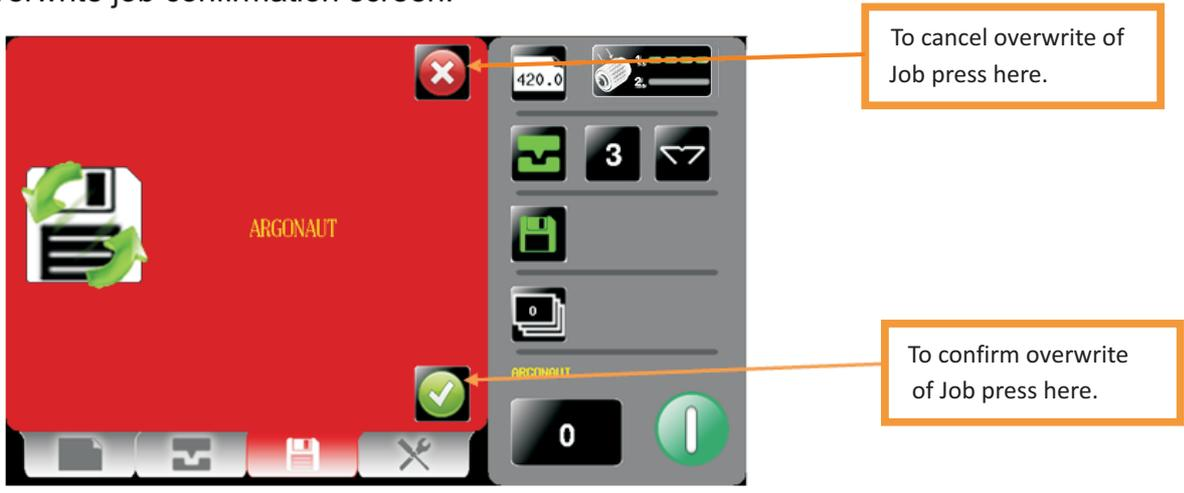

Delete job confirmation screen.



To cancel deletion of Job press here.

To confirm deletion of Job press here.

Running the machine

Run the job as described on page 13. The machine will complete its creasing operation if a sheet has already been fed through the paper gate.

Paper jamming

In the event of a paper jam occurring whilst the machine is operating, select the Tools

tab  at the bottom of the touch screen, the display will change to that shown

below. Press the system switch down and then select the right or left arrows, to inch the paper forwards or backwards.



Setting the machine to operate in manual sheet feed mode

In order to feed heavy stock, very small or very large sheets, embossed or even irregular shaped sheets, it may be necessary to feed the sheets manually. The machine can be programmed and set up in exactly the same way as explained when operating the machine automatically. However, the paper gate must be raised to its highest position for the sheets to be fed freely. Operating the machine in manual sheet feed mode will also require the suction length to be continuous in order to accommodate various types of stock. Therefore, the feed should be set to **Stream Feed** (Vacuum Drum position 2) see page 10.

The machine can now be started by activating the System switch to 'on'. **Do not activate the Compressor switch.**

Select the  icon on the touch screen and begin to slide the sheets individually through the paper gate until they are driven by the drive belts.

To stop feeding the sheets, select the  icon on the touch screen and switch the System Switch off.

The Stacker Assembly

The stacker unit on the machine is used to catch the sheets once they have been creased or perforated.

Setting the Stacker assembly

1. Assemble the stacker unit to the machine as shown in fig 13.1 below.

Important

Ensure that the stacker unit has been assembled to the machine properly. However, if it has not, the connection on the magnetic switch will be broken and the machine will not operate (see Trouble shooting pages for details).

There are two side guides on the stacker unit; a left handed (fixed) guide and a right handed (movable) guide held on by a magnetic strip. There is also a left hand extension guide. The guides will control the way in which the paper is collated by setting their positions on the stacker bed.

2. Place a single sheet (from the stack to be creased / perforated) on to the stacker bed against the fixed 'left hand' guide.
3. Position the 'right hand' side guide on to the stacker bed leaving a minimum clearance of approximately 1mm each side of the sheet.

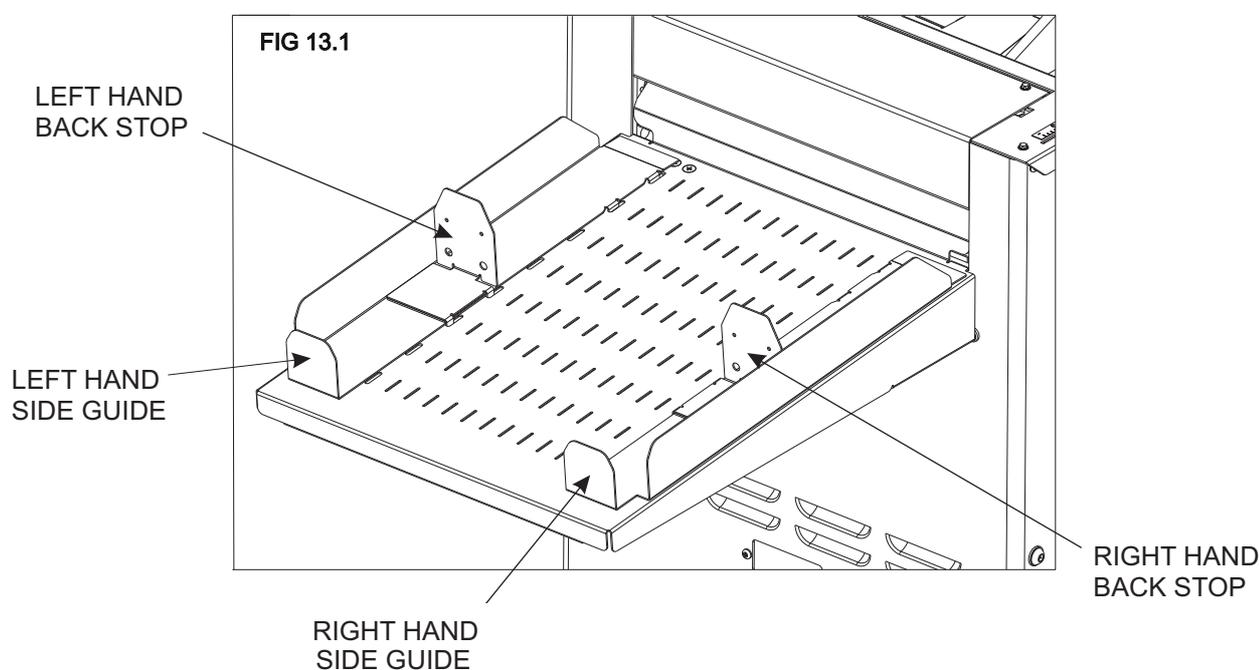

The Stacker Assembly

4. Whilst the sheet is between the two guides on the stacker bed, set the distance between the top of the sheet and the backstop flanges to approximately 5mm.
5. For shorter sheets, the back stop can be used (as shown in FIG 13.1) to adjust the position of the paper stack.



TIPS

- The magnetic back stop supplied with the machine can also be used as a tool holder as demonstrated in the photograph (left).

Perforating

Once the machine is set-up, the Atlas C100 can be used to perforate or crease.

Note

1. Perforating and creasing can be carried out simultaneously. However, if any adjustment is made to the roller tilt mechanism in order to compensate for the perforation line being 'out of square', this may effect the accuracy of the crease. If this occurs creasing and perforating must be carried out as separate operations.
2. By adjusting the outfeed drive tyres relative to the drive hubs it is possible to steer the sheet, (i.e. By placing the tyre on top of the hub one side of the paper will steer faster on that side).

The components and tools required to install the perforator are contained in the despatch kit supplied with the machine, they are listed below.

- 1 off Set of standard perforation '56 tooth' blades.
- 1 off Set of standard hardened anvils.
- 1 off Perforator stripper.
- 1 off Scoring wheel
- 1 off 3mm bondhus wrench / allen key
- 1 off 2mm bondhus wrench / allen key



The perforator blades are split into two matching halves and are fitted to the drive wheels as shown in the photograph using the four screws supplied.

A hardened anvil is fitted to the drive hub as shown in the photograph also using the four screws supplied. Again the anvils are made from matching halves.

Important: The perforator blades are very sharp and care must be taken whilst handling. Do not mix the matching pairs of blades or anvils.

Perforating 'Spares' kits

For perforating and other types of paper, various spares kits are available which can be assembled to the machine in the same fashion. They are listed below along with a range of scoring wheels,

Perforating blades	56 teeth	Part Number	1-99-41	- Standard stock / fine perforations.
	28 teeth	Part Number	1-99-12	- Medium stock / medium perforations.
	20 teeth	Part Number	1-99-10	- Heavy stock / coarse perforations.
Anvils	Standard	Part Number	1-99-35	- For all blade types

Perforating

All of the blades and anvils are supplied with fixings.

***Perforator stripper** Standard Part Number **78-013**

*It is recommended that for multiple perforations, a separate perforator stripper is used for every perforating blade set fitted in the creasing unit.

Setting the machine

1. Turn the mains supply to the machine 'off'.
2. Remove the stacker unit and open the exit guard.
3. Locate and remove the blades / anvils from the despatch kit supplied with the machine.
4. Using the 2mm allen key (supplied), loosen the drive wheel that is to accommodate the blades.
5. Slide the drive wheel away from any obstructing drive wheels or hubs in order to mount the blades.

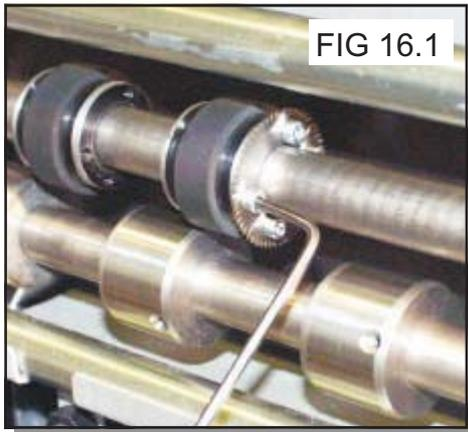

6. Using the 2.5mm allen key (supplied), take one of the matching pairs and mount on to the drive wheel. Do not secure the blade.
7. Mount the other matching pair to the drive wheel as shown (fig 16.1). Secure the blades to the wheel ensuring not to over tighten grub screw.
8. Mark on a single sheet the desired perforating position. Feed the sheet through the machine manually until the mark can be seen. Use this mark to assist in fixing the position of the perforating drive wheel to the roller drive shaft.

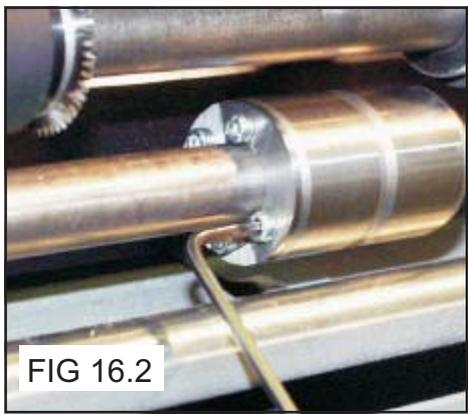

9. Using the 2mm allen key, loosen the drive hub nearest the perforating drive. Slide the drive hub away from any obstructing drive wheels or hubs in order to mount the anvils.
10. Using the 2.5mm allen key, take one of the matching pairs of anvils and mount to the drive hub. Do not secure the anvil.

Perforating

11. Mount the other anvil ensuring that they have matched on the drive hub. Secure the anvil to the hub ensuring not to over tighten grub screw as shown in fig 16.2.
12. Slide the drive hub towards the perforating drive wheel until there is a clearance of 0.5mm.
13. To prevent damage to the blades or the anvils, do not force the drive wheel against the hub.
14. Fix the perforator stripper adjacent to the drive wheel and blade as shown.
15. Operate the machine and test the perforations for form.

It is important that the drive hubs are arranged evenly across the width of the paper in order to reduce the risk of jamming.

For multiple perforations repeat the above procedure.

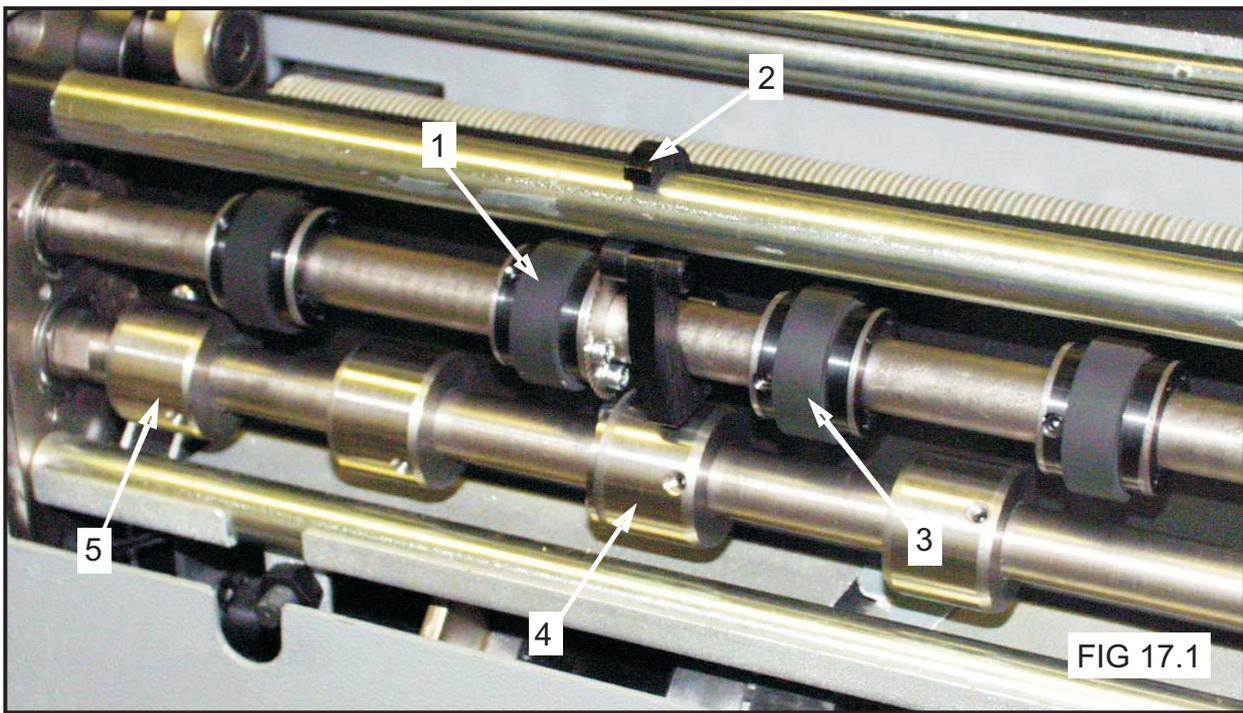

Fig 17.1 Demonstrates a typical set-up for perforating sheets.

- | | |
|---|-----------------------------------|
| 1 - Perforating drive wheel with mounted blades | 4 - Drive hub with mounted anvils |
| 2 - Perforator stripper | 5 - Standard drive hub |
| 3 - Standard drive wheel | |

Always remove blades and anvils once the perforating operation has been completed to avoid marking on digital or delicate media.

The Blade Assembly

Adjusting the blade pressure (no paper required)

- (i) Switch the power 'on' by turning the Emergency stop button clockwise to release the safety latch.
- (ii) Select the Tools tab  at the bottom of the touch screen, the display will change to that shown below.
- (iii) Select the up arrow to move the blade to the Top Dead Centre position.

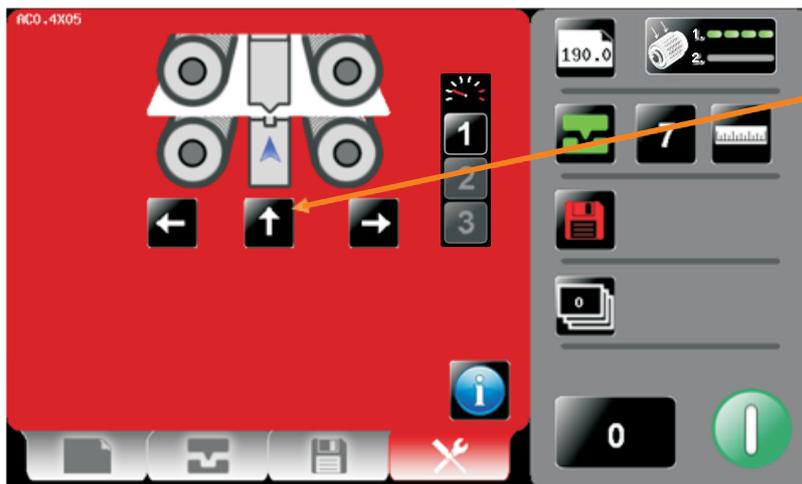

Click on Up Arrow to put Anvil into Top Dead Centre position (TDC)

2. Raise the exit guard
3. Using a 6mm allen key, unlock the shoulder bolts (labelled with scale transfer) positioned at each end of the creasing blade.
4. Turn the adjustment cam to adjust the blade pressure. Increasing the gradient on the scale will increase the blade pressure.
5. Ensure that the shoulder bolts are locked after setting.

The diagram below demonstrates the adjustment of the blade pressure

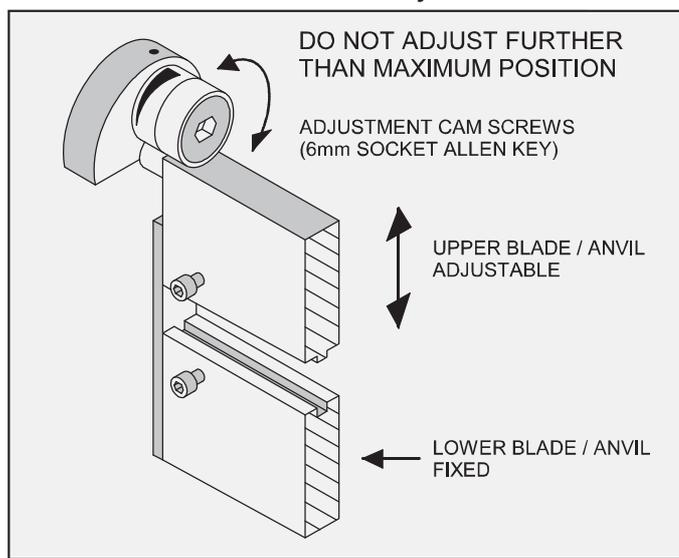

The Blade Assembly

Adjusting the blade alignment

It is extremely important that the blade and anvil assembly within the creasing unit is correctly aligned. Misalignment of the blade or anvil can lead to damaged profiles and subsequently poor quality creasing so it must, therefore, be corrected immediately. If the blade set is misaligned, the media being driven will be subject to scoring or even tearing at any point along the crease line. **Please note that to avoid damage to the blade set, adjustment should only be made in small increments.** The below sketch demonstrates how the blade alignment can be carried out.

Adjustment can be made at either of the blade or anvil. The two clearance holes positioned above the roller tilt mechanism are the front alignment (one for blade, one for anvil). The two holes are repeated on the back of the machine for the back alignment.

1. Remove the stacker unit.
2. Unlock and centralise the roller tilt mechanism in order to locate the heads of the front alignment screws.
3. Using a 3mm allen key, loosen the cap head type locking screws located on the front face at both ends of the blade /anvil as shown below.
4. Using a 4mm allen key, locate the two front or back alignment screws in the side frame in order to adjust the blade / anvil.
5. The upper screw of the two, will adjust the upper blade / anvil whereas the lower screw will adjust the lower blade / anvil both in very small increments.
6. In order to obtain the required position, adjust either the blade or the anvil by a small amount and then operate the machine to test the form of the crease. Repeat the exercise until centralisation is located.
7. Using a 3mm allen key, lock the cap head type screws (as per step 3) on both the upper and lower blade / anvil.

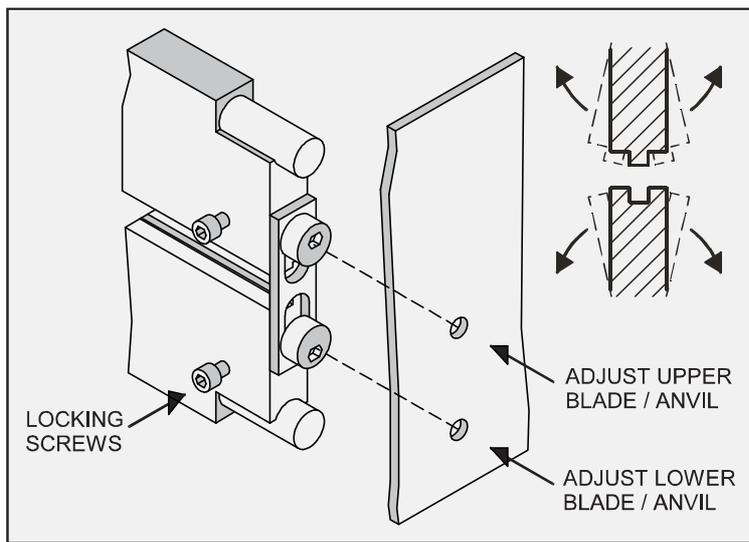

Replacing Blade Set

1. Before removing the blade assembly, ensure that the lower blade / anvil is NOT at 'top dead centre', Switch the machine off.
2. Remove the stacker unit and lift the exit guard.

Blade Extractor Tools

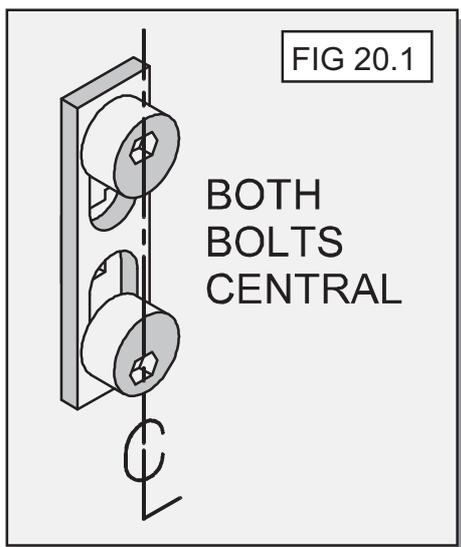
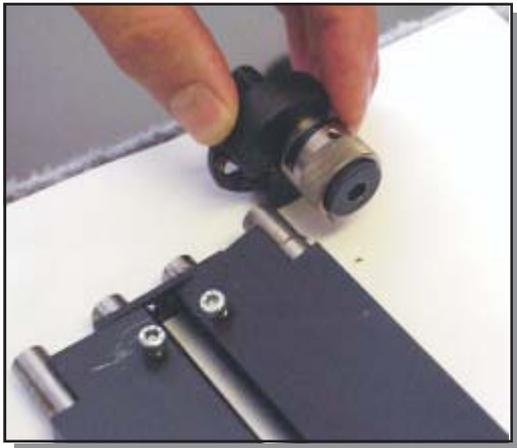

3. Using a 6mm allen key, loosen the socket head screws located inside the blade adjustment cams. Remove the screws and the blade adjustment cams.
4. Insert the blade extractor tools (70-055-01 & 70-055-02) into the holes in the adjustment links, as shown. Push downwards on the handles of the blade extractor tools to release the blade assembly from the power links.
5. Slide the blade assembly out of the creasing unit and lay it on a flat surface.
6. Slide the adjustment links away from the dowels located in the ends of the blades / anvils as shown in the photograph (left)
7. Place the new blade set into position. Check that the eccentric shoulder bolts on the link plates have been positioned as shown in fig 20.1.
8. (Upper blade / anvil only)
Slide the adjustment links onto the dowels.

9. Slide the new blade set into the slots of the creasing unit as shown in fig. 21.1.

Locate the blade extractor tools into the holes in the adjustment links as shown. Pull the handles of the blade extractor tools upwards to engage the blade assembly back into the power links.

10. Set the cam graphics for both ends of the blade / anvil to their lowest point on the scale (ie. When the mark on the scale reaches the mark on cam holder) Fasten the socket head screws on the adjustment cams until they are tight.

Replacing Blade Set



11. Push the exit guard down and replace the stacker assembly before operating the machine.
12. Switch the machine on and test the crease for form.

If the pressure and the alignment of the crease is not to a satisfactory level, see pages 31 - 33 to adjust the creasing line.

'Spares' kits

In the event of any damaged or lost components within the blade assembly, spares kits are available on request. However, components within the blade set can not be ordered separately ie single blade or anvil.

Standard Blade set

Part number 76 - 213 - 01

Consisting of a standard blade and anvil, blade brushes, blade links and alignment bolts.

Extra Narrow Blade set

Part number 76 - 213 - 03

Consisting of a narrow blade and anvil, blade brushes, blade links and alignment bolts.

Trouble Shooting

Paper crease out of square

- Check that the sheets are all square and exactly the same size before loading the stack on to the table.
- Check that the roller tilt mechanism is correctly set and locked in position.
- Check that the adjustable side lay has been correctly positioned ie. No further than 0.5mm from the paper stack.

Paper jamming

- Check that the leading edge of the paper is not being damaged by the paper gate. If this is occurring, check that the suction slot and the paper gate have been correctly set.
- Check that the first crease position is not too close to the leading edge of the paper. A minimum distance of 32mm is recommended.

Machine will not start

- Check the power supply to the machine.
- Check that the emergency stop button has been released.
- Check that the exit guard is down.
- Check that the stacker unit is located correctly and has not been disconnected from the magnetic switch.
- Check that the lower blade / anvil is connecting to the home switch (mounted below the lower blade / anvil).

Paper not feeding

- Check that the paper stack is not too high or too heavy for the feeder. The height of the paper stack should be defined by the weight and the size of the stock being creased.
- Ensure that the adjustable side lay is not pressed against the paper stack. However, if the clearance between the adjustable side lay and the paper stack is too great, the air supply will escape instead of blowing through the paper thus making it difficult to feed.
- Check that the clearance between the paper gate and the suction roller is not set too low.
- On digital media, the feeding performance may be improved if the leading edge of the stack is trimmed before loading onto the Machine.

Trouble Shooting

- Check that the air distribution has been correctly set.
- Check that the air separation has been set high enough to feed the sheets.
- For heavy stocks, very small or very large sheets, embossed or even irregular stock, it may be required to feed the sheets manually - see page 25 for instructions.



Machine not counting

Open the exit and remove the blade set (see pages 33-34) to access the dual sensor post located in between the drive rollers. Using a soft brush, clean the visible sensor on the end of the post.

Use the brush to clean the sensors between the post and the bottom paper guide which are not visible.

Photograph (left) shows the dual sensor post containing the sensors.

Paper jammed under paper gate.

If paper gets jammed under the paper gate the vacuum drum will stop rotating, this is a safety feature. Remove the paper and re-adjust the paper gate.

Error Screens

- **Sheet did not arrive.**

If the machine stops and error message 01 is displayed on the touch screen, this indicates that the paper did not arrive at the end of the suck process; so the machine timed out. Press the green tick button and then press the start button.



- **Paper Crunch**

If the machine stops and error message 02 is displayed on the touch screen, this indicates that a paper jam has been detected.

Press the system switch down and then select the right or left arrows, to inch the paper forwards or backwards. See page 39 that describes how to remove paper jams. Press the green tick button and then press the start button.

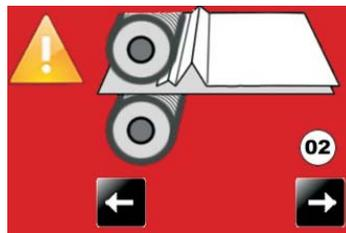

- **Double Sheet Feed**

If the machine stops and error message 03 is displayed on the touch screen, this indicates that a double sheet feed has been detected. Check that the paper gate has been set correctly. Press the green tick button and then press the start button.

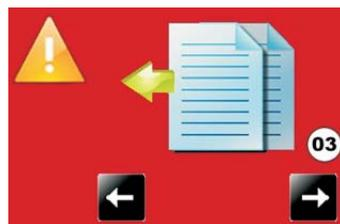

- **Blade Not Home**

If the machine stops and error message 04 is displayed on the touch screen, this indicates that the lower blade / anvil has not made contact with the HOME switch. i.e. blade still in top position. Switch the machine off and remove the blade set and ensure that the area is free from obstructions. Return the blade set to the creasing unit and switch the machine on. Operate the machine in the normal sequence, if the display continues to read error message 04 it is advised to contact a Service Engineer immediately.

Trouble Shooting

Error Screens (Continued)

- **Blade Not Home**

If the machine stops and error message 04 is displayed on the touch screen, this indicates that the lower blade / anvil has not made contact with the HOME switch. i.e. blade still in top position. Switch the machine off and remove the blade set and ensure that the area is free from obstructions. Return the blade set to the creasing unit and switch the machine on. Operate the machine in the normal sequence, if the display continues to read error message 04 it is advised to contact a Service Engineer immediately.

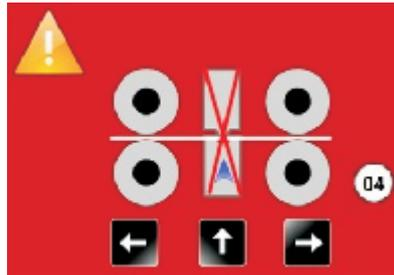

- **Overlap**

If the machine stops and error message 13 is displayed on the touch screen, this indicates that the 'Lead Edge Sensor' has seen a sheet subsequent to the first one as being longer. Again this could actually be a longer sheet, OR it could be a sensor problem (if it is a recurring problem). Check that the paper gate has been set correctly.

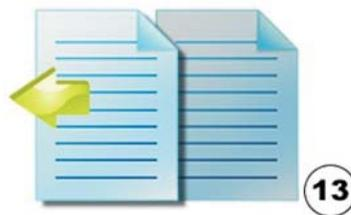

Recommended weekly operator maintenance

- Clean all sensors
- Clean in feed rollers and output drive hubs using the cleaning kit provided (Cleaning kit part number 90-018)
- Remove and clean the blade assembly
- With the blade assembly removed, clean the slots and surrounding area within the creasing unit.

Technician Maintenance

It is recommended that your machine is fully serviced at least once every six months by a factory trained Service Engineer.

ITEM	PART NUMBER	QTY	DESCRIPTION
1	70-148	1	OPERATORS MANUAL
2	90-018	1	ROLLER CLEANING KIT
3	650-040	1	POWER CORD CE UK C19 3Pin 16A 2.5Mtrs.
4	617-003	5	STEEL BALL - Ø20
5	78-007	1	MAGNETIC BACK STOP ASSY.
6	403-01-030-006	12	SCREW - SOCKET CAP HEAD - M3 x 6 LG
7	409-01-040-004	1	SCREW - SKT. SET FLAT PT. - M4 x 4 LG
8	620-007	1	HEXAGON BALL DRIVER 2mm
9	620-020	1	HEXAGON BALL DRIVER 2.5mm
10	620-004	1	ALLEN KEY 4mm
11	620-026	1	BONDUS L WRENCH 4mm
12	620-028	1	BONDUS L WRENCH 3mm
13	620-033	1	BONDUS L WRENCH 6mm
14	624-018	1	DISPATCH BOX
15	70-055-01	1	BLADE EXTRACTION TOOL - OP SIDE
16	70-055-02	1	BLADE EXTRACTION TOOL - LAY SIDE
17	08-041-02	1	SLITTING ANVIL - UNDERSIZE.
18	08-066	1	SLITTER PERF BLADE 28T
19	624-017	3	SLITTER/SCORER PK - STYLE 0212/40X40X20

WARNING.....

THE BLADES FOR ANVIL AND PERFORATING SETS ARE SUPPLIED AS MATCHING PAIRS AND SHOULD NOT BE MIXED OR LEFT UNPROTECTED OR SERIOUS DAMAGE MAY RESULT.

ACCESSORIES AND OPTIONS

ITEM	PART NUMBER	DESCRIPTION
1	1-99-10	PERFORATING BLADE SET 20T (Card)
2	1-99-12	PERFORATING BLADE SET 28T (Single sheets)
3	1-99-41	PERFORATING BLADE SET 56T (Fine perforations)
4	1-99-35	ANVIL SET USED WITH ABOVE BLADE SETS
5	76-213-03	BLADE SET - EXTRA NARROW
6	70-082-02	ANTI-STATIC KIT
7	94-073-02	SIDELAY EXTENSION - NARROW SHEET

ACCESSORIES....

....May be obtained from your dealer and fitted to your machine using the instructions supplied, or by reading your operators manual.

OPTIONS....

....May also be obtained and fitted by your dealer. You should not attempt to fit options as specialist tools and knowledge are required.

RECOMMENDED SPARES

PART NUMBER	DESCRIPTION
93-021	FEED BELT
609-011	'O' RING Ø20
94-028	LOCK PIN ASSEMBLY - Side Lay
613-365	EMERGENCY STOP SWITCH
652-011	SWITCH - LOW CURRENT COIL - BLACK ROCKER
652-043	SWITCH - 240 VOLT COIL - 20A - BLACK ROCKER
75-472-01	MINI ITX MOTHERBOARD (CONFIGURED)
75-455-01	CONTROL PCB ASSEMBLY
174-06-01	SMALL STEPPER DRIVER - LOW POWER - PCB ASSY
174-19-01	RS232 ADAPTOR PCB ASSY
125-21-02	DUAL STEPPER DRIVE PCB ASSEMBLY
75-06-01	TOUCH SCREEN ASSEMBLY - 7"
76-272	PSU ASSEMBLY - ATX12V - 300W
655-015	PSU UNIT - SWITCH MODE - 24V
655-016	PSU UNIT - SWITCH MODE - 48V
76-156	BLADE POSITION SENSOR
76-168	PAPER GUIDE ASSEMBLY - Bottom Sensor
76-166	PAPER JAM SENSOR ASSEMBLY
76-167	UPPER SENSOR ASSEMBLY
76-169	BLADE POSITION SENSOR-LEAD
76-255	LEAD - FOLD COMPENSATION SENSOR
98-013	ANTI-STATIC BRUSH
609-022	'O' RING Ø32
606-035	KNOB - Roller Tilt
76-109	POWER LINK BEARING
76-213-01	BLADE SET - Standard
76-042	DRIVE BELT - FEED BED
607-041	TIMING BELT - 110XL 037
607-042	TIMING BELT 160XL
607-048	TIMING BELT TWIN GRIP - 200 DXL 050
608-019	SHOULDER BOLT
76-082	PERFORATOR - DRIVE HUB ASSEMBLY
175-28-01	BUTTERFLY VALVE - STEPPER
76-240	STEPPER DRIVE MOTOR ASSEMBLY
76-241	STEPPER BLADE MOTOR ASSEMBLY
75-425	LEAD VACUUM DRUM ASSEMBLY

FUSE POSITIONS & RATINGS

(POSITION ET CLASSIFICATION DES FUSIBLES)

